



Christine

12.8T BP
COASTAL TUG



Contact
+44 (0) 1626 866066
tmsmaritime.co.uk



GENERAL

Type of Vessel: Stantug 1604
Builder: Damen Shipyard, NL
Build Date & Place: 2004, Romania
Classification: BV 3/3 Coastal Tug
Certification: MCA Workboat Cat 2 (60 miles) 12 pax

DIMENSIONS

Length OA: 16.89m
Breadth OA: 5.29m
Moulded Depth: 2.51m
Draft: 2.25m

PERFORMANCE

Cruising Speed: 10knts
Bollard Pull: 12.8t

PROPULSION

Main Engines: 2 x Caterpillar 3408TA (Keel cooled)
Total Power: 960bhp (716Kw) @ 1800 rpm
Transmissions: 2 x Reintjes WAF164 5.044:1
Propulsion: 2 x 1300mm 3-blade propellers in nozzles.

AUXILIARY EQUIPMENT

Generators: Lister/Stamford LPW4-11Kw (Keel cooled)
Transfer Pumps: 50lpm
Electrical System: 24V DC and 220V shore supply

DECK EQUIPMENT

Deck Capstan: 1.3t @ 9m/min
Towing Hook: Mampaey - 15t SWL
Welding Set: Installed on request
Burning Set: Installed on request

TANK CAPACITIES

Fuel Oil: 13.7m3
Fresh Water: 0.75m3

ACCOMODATION

Large Wheelhouse with air conditioning and day accommodation.
Below deck 1 x 4 person cabin, WC and shower, galley.

NAVIGATION & COMMUNICATION

Searchlight: Seematz Pesch 250W
Compass: Cassen & Plath - Kotter Type
Radar: Furuno FR1921
GPS: Furuno GP31
Echo Sounder: Furuno LS6100
VHF Radios: 1 x Sailor RT2048 & 1 x Sailor RT4822DSC
Handheld VHF: 1 x Sailor DSC
Navtex: Furuno NX300
Chart Plotter: PC with Euronav Electronic Charts
AIS: SMR Transponder Type
EPIRB: Tron 40s 406mhz

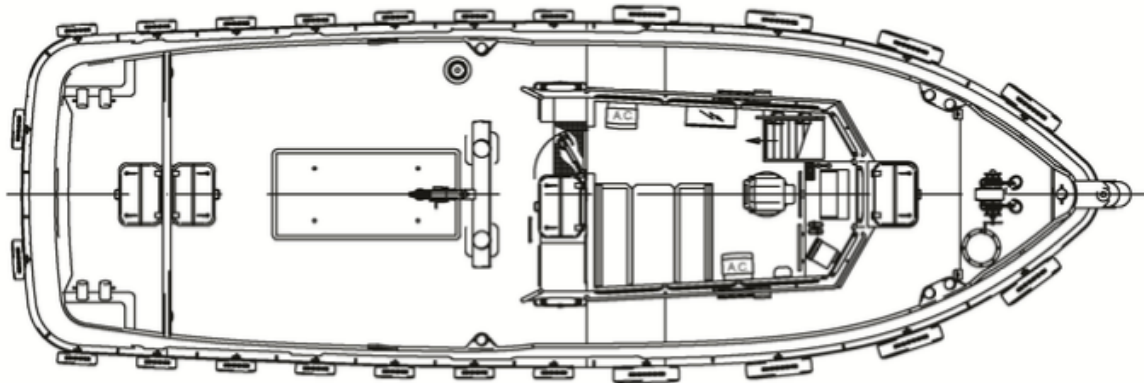
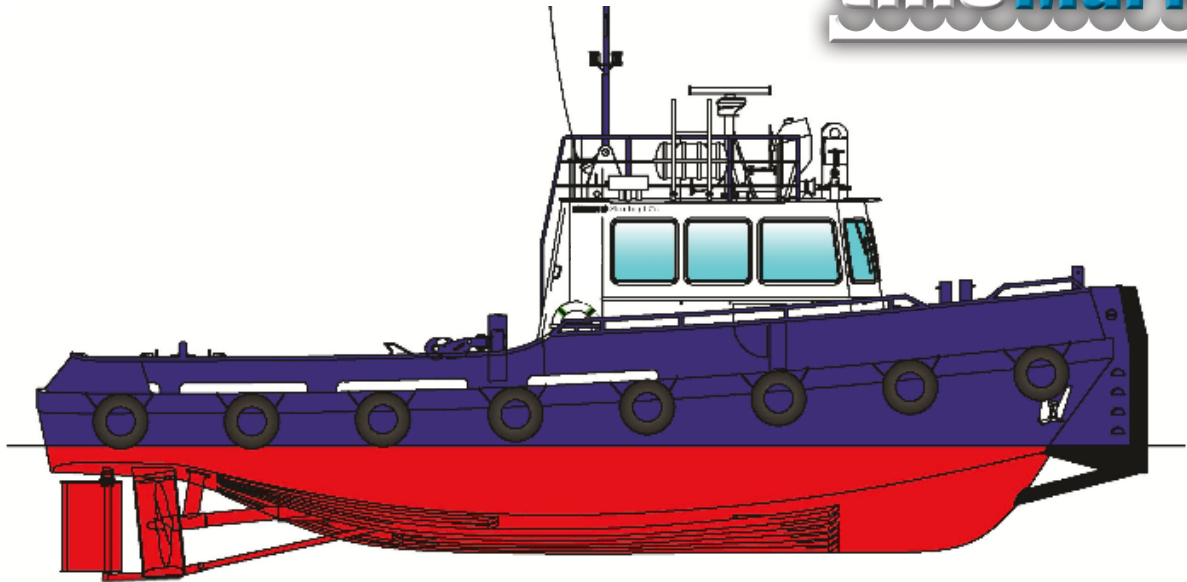

Maindeck

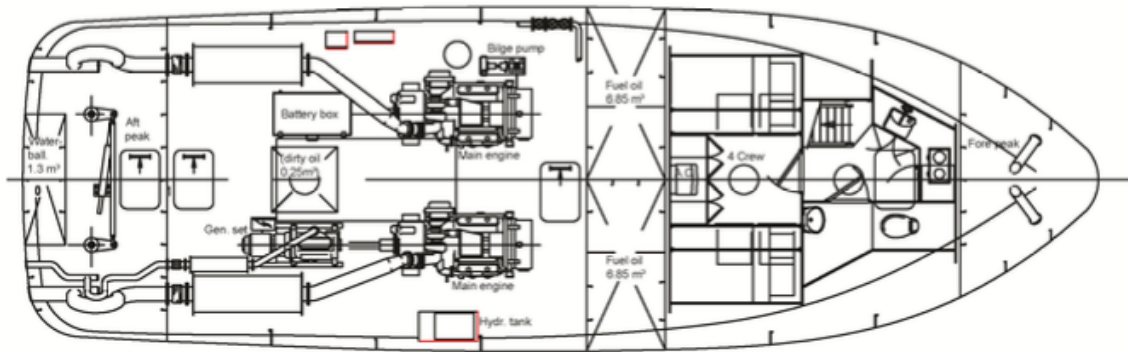

Below Maindeck

