



HENRIKSEN

REDUCING OPERATIONAL RISK

NEW!

The Henriksen Liferaft Hooks (HLH) are off-load crane hooks designed for lifting Liferrafts and Man-Over-Board boats with a total weight of up to 3 500 kg. The HLH hooks provide an automatic release that - if activated - releases the load automatically when the craft is waterborne. The hooks also have a manual on-load emergency release as a supplement to the automatic release.



NEW!

The Henriksen Towing Hooks (HTH) is one of the latest addition to the Henriksen hook product range. The towing hooks are made with same high quality in design and materials as the rest of our range. The towing hooks are suitable for all kinds of maritime towing and hauling operations, both for smaller work boats, rescue boats or other vessels for use in any towing operation up to 10 000 kg bollard pull (BP).

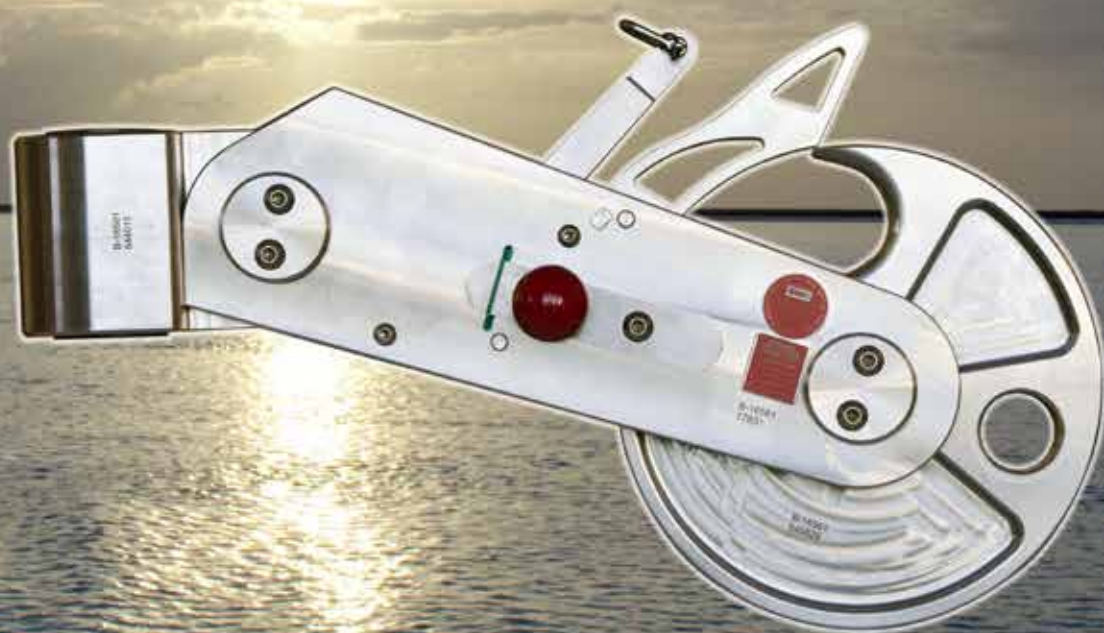

TABLE OF CONTENTS**HOOKS**
SAFETY QUICK RELEASE HOOKS**Introduction**

About Henriksen and Henriksen Hooks.....	6
Certification, Approval and Training.....	7
Exchange and Recertification Programs.....	8
Safe Launch Procedure	9
Glossary.....	10
Product Range.....	12

Boat-mounted Lifting Hooks

Manual Off-load Hooks with Geared Handle - HMKG	16
Manual Off-load Hooks Original - HMKST.....	18
Manual Off-load Hooks Small - HRH.....	20
Manual Off-load Hooks Compact - HHSM.....	22
Remote Release Hooks Electrical - HHSR	24
Remote Release Hooks Manual - HMKR.....	27
Norsok Compliant Hooks - NORHMK	34
Twin Hooks Systems - HMKTW	36

Crane-mounted Lifting Hooks

Crane Hooks - HCH(T).....	39
Liferaft Hooks - HLH.....	42

Bow-mounted Hooks

Painter Hooks - HPH.....	44
Capture Claw Painter Hooks - HPHA	46

Stern-mounted Hooks

Towing Hooks - HTH	48
--------------------------	----

Safety Systems

Integrated Henriksen System - IHS.....	50
Increased Operational Awareness System - Liftview.....	52
Increased Operational Awareness System - Awarelight	53

Accessories

Bolt set.....	54
Shims.....	55
Swivel Joints - HSL.....	56
Lifting Rings - HLR.....	57
Painter Rings - HPR.....	58

INTRODUCTION

HOOKS
SAFETY QUICK RELEASE HOOKS

About Henriksen

H. Henriksen AS is a technology company with a long and proud history within the maritime and the offshore sector. The company has a strong position within safe MOB boat lifting operations, Launch & Recovery systems for offshore vessels, Oil Spill Recovery systems and Entering and Boarding Systems for both maritime and urban environments.

HOOKS
SAFETY QUICK RELEASE HOOKS

REBS
RAPID ENTERING & BOARDING SYSTEM

SPILLRECS
OIL SPILL RECOVERY SYSTEMS

MARITIME
MARITIME & OFFSHORE EQUIPMENT

Henriksen was founded in 1856 based on the maritime industry, and is located in South-East Norway.

Henriksen has a brand vision that is rooted in over 160 years of experience. Our vision has been shaped by our founding fathers and many generations of forefathers. Their first hand experience and challenges has over time proven the true overreaching vision to for Henriksen to always look forward with the intent of creating safer operational conditions. We are committed to create safer operational conditions world wide. The Henriksen slogan is “Reducing Operational Risk”.

Henriksen Hooks

“Henriksen HOOKS” is a well established trademark amongst professionals in the maritime and offshore segment. The first off-load hook was made by Henriksen as early as 1978. Henriksen Hooks are designed to increase safety and efficiency when MOB boats are launched and recovered on ships and offshore installations. The operational safety, simplicity and working reliability of the Henriksen Hooks is very important for our customers and users. We also provide an established and operational exchange and re-certification program for our users. The brand vision is passed on down to the Hooks segment with the slogan: “A safe lifting operation”.



CERTIFICATION, APPROVAL AND TRAINING

HOOKS
SAFETY QUICK RELEASE HOOKS

The Henriksen Hooks are particularly safe and effective in boat lifting operations. The hook itself is mounted on the boat and features a “click-in-place” connection, making launch and recovery much safer and easier than with a sling. The lifting ring that clicks in place in the hook weighs only 2 - 6 kg and is therefore easy to catch and handle. The lifting ring also features a double handed grip which makes it safe and easy to place into the hook.

The capacity of our hooks range from SWL 1 500 kg to SWL 22 500 kg. We do also offer larger hooks, but not from our standard inventory. We often provide our customers with comprehensive systems, based on the Henriksen Hooks. Many of our professional users also require extra surrounding equipment in order to implement the systems on their vessels. We have considerable experience with these kind of challenges.

Certification and Technical Approval

Lifting equipment for manned vessels such as FRCs, RIBs, military vessels and MOB boats is subject to strict regulations. All our single point lifting hooks receive the wheel mark after receiving the proper technical approval. The wheel mark signifies that we prove every hook we manufacture according to procedures and standards that have been approved by Det Norske Veritas (DNV-GL). Additionally, DNV-GL witnesses as we carry out the qualification test (destructive). When the test regime and calculations have been approved and accepted, are we issued a certificate from DNV-GL that gives us the right to sell the products with a wheel mark. Every lifting hook we produce is tested to 2,5 times SWL and undergo a thorough qualification test regime prior to delivery.



H. Henriksen Training Maintenance & Service System (HTMSS)

The Henriksen Hooks are designed to withstand heavy duty work on ships and boats all over the world. Design, Training and Maintenance are key elements, that all has to work well together to ensure safe operations. The laws and regulations regarding lifting devices requires a conscious user and owner of the systems.

User Training

The users should have regular training with the system. This should be regulated in the training plans for the ship or boat. Training is important to prevent accidents.

Annual Inspection

Yearly, the hook and hook system must be inspected by a trained inspector. H. Henriksen offers on-line training, the course last for 2 hours. The scope is to learn the system and to be able to do a qualified inspection of the hook. There shall be a service record on board to document the yearly inspection (whom and when and any findings).

Disclaimer

Although great efforts have been made in order to produce accurate and correct information in this catalog, there is always a possibility that an error has occurred. Designs and dimensions of the products listed in this catalog were correct at the date of publication but are however subject to change without notice. Please ask for our confirmation in cases where accuracy is critical. Typographical and pictorial errors that are brought to our attention will be corrected in subsequent issues.

EXCHANGE AND RECERTIFICATION

HOOKS
SAFETY QUICK RELEASE HOOKS

Exchange and Recertification

A hook (and if applicable, the swivel joint) shall have major service after 5 years. Each hook is delivered with a certificate stating the expiry date. Recertification is a program where the customer sends the hook to us for rehabilitation and re-testing. During service the complete system will be dismantled and the main bolt will be changed together with any parts that have significant wear & tear. Finally the system/hook is tested just as if it was new (including the 2,5 x SWL test). The hook/systems we send back will normally appear as brand new. A recertification is usually completed within a couple of weeks, and the serviced hook will be ready for 5 more years of heavy service.

H. Henriksen Exchange Program

Most customers use the Henriksen exchange program. That means they require a refurbished hook when the expiry date is closing in. H. Henriksen will then send (and invoice at full price) a refurbished hook that has approx. the same age as the hook that need service. The customer exchanges the hook when possible, and then return the expired hook to H. Henriksen. H. Henriksen will then credit 30 - 70% full price of a hook, depending on hook model.

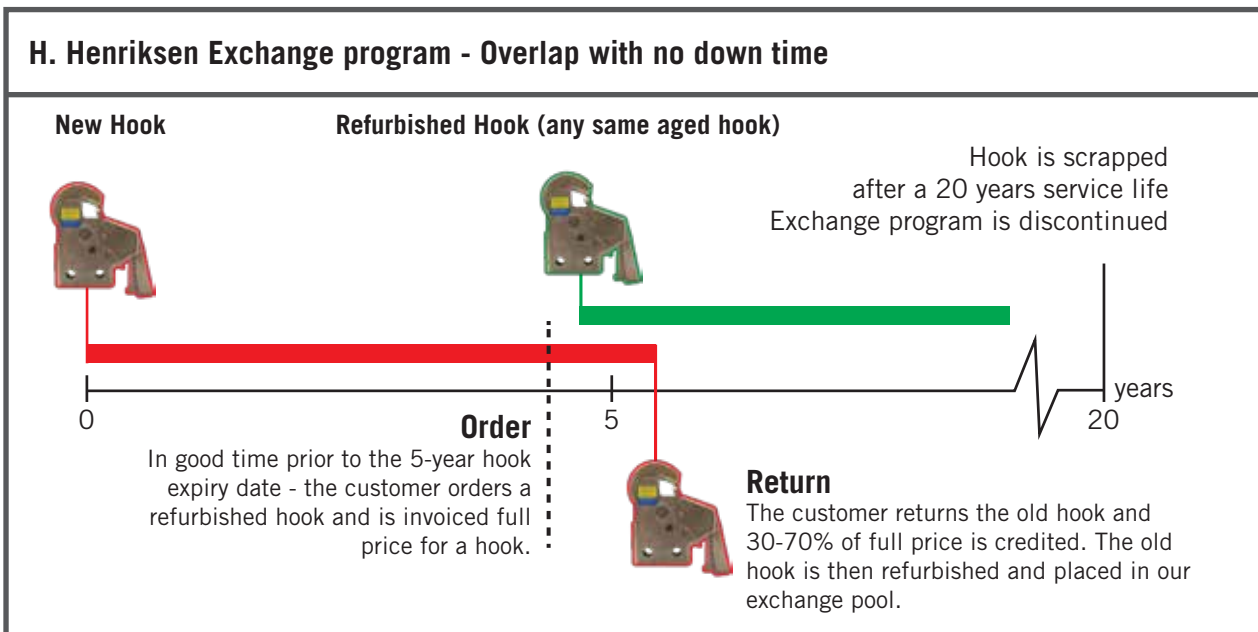

H. Henriksen Recertification Program

Other customers have the possibility to send the hook to H. Henriksen and wait until the same hook is returned. This is called the H. Henriksen recertification program. The same will happen during the service but H. Henriksen normally will need 2 - 3 days in the workshop plus transport, meaning the boat will be without it's hook for a period. The cost of the service is 30 - 70% of full price of a hook, depending on hook model.

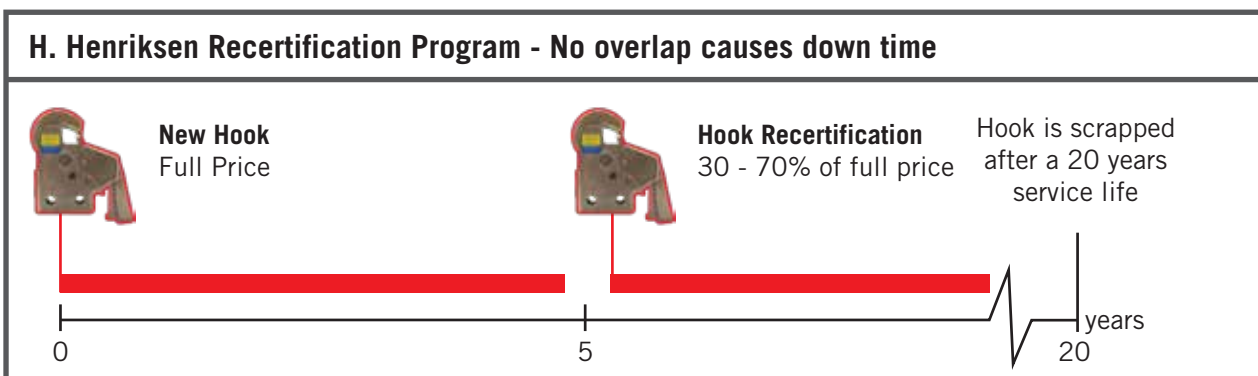

SAFE LAUNCH PROCEDURE

HOOKS
SAFETY QUICK RELEASE HOOKS

SAFE LAUNCH PROCEDURE WITH SINGLE POINT HOOK AND PAINTER HOOK

By placing a Henriksen Painter Hook in the bow of a boat and connecting it to a tow line, you are ensuring that the boat is kept in the correct direction and position during both launch and recovery. The Integrated Henriksen System ensures that the safe procedure as shown below is followed, by eliminating the risk of releasing the painter hook before the main hook.

1. Before launch

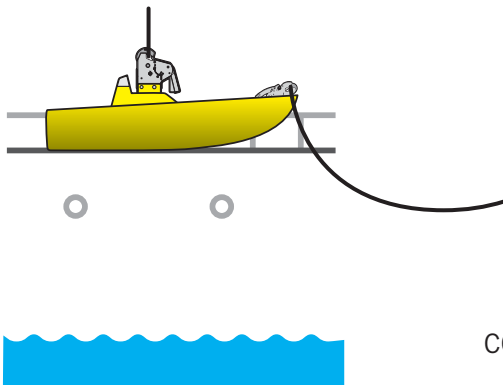

2. Lowering

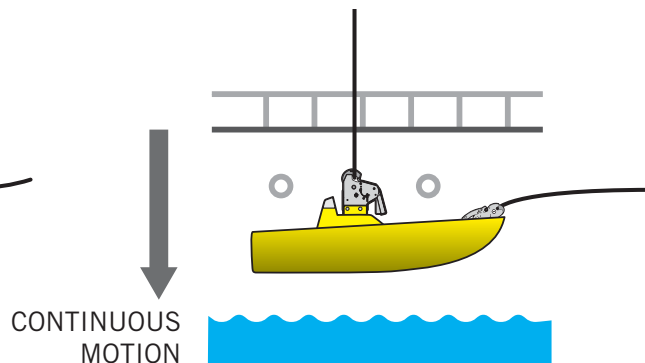

3. Activate hook release when boat is clear of all objects and closing in on the water

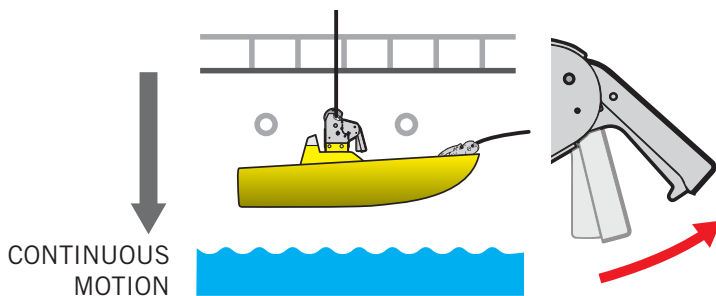

4. Hook opens automatically when the boat hits the water

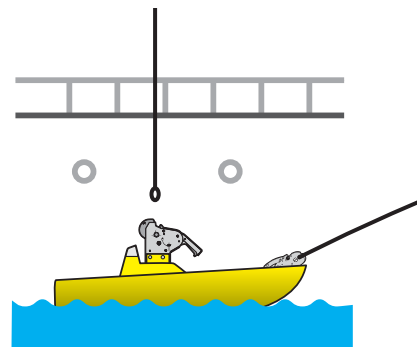

5. Release painter when crew is ready

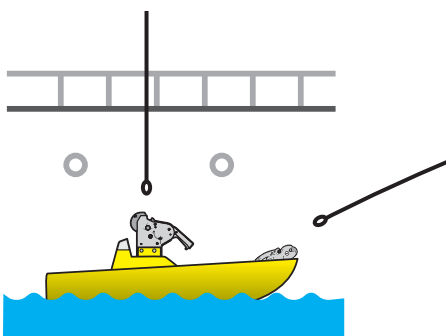

We recommend using
Henriksen Painter Hooks



GLOSSARY

OFF-LOAD HOOKS

Most Henriksen Hooks are off-load hooks, this means that the hook cannot release the boat until the boat hits the water. This means that you avoid dangerous and unintentional hook releases which causes the boat with crew members to drop from large heights. This is a very dangerous event and does unfortunately happen all too often with on-load hooks. It is the geometry of the off-load hook itself that eliminates this possibility, as the hook is unable to release until the load has been off-loaded, hence the term off-load hook. Below is an illustrated explanation.

Hook Closed

When the hook is in the closed state, a manual latch prevents the hook element from rotating, while a spring loaded pawl keeps the lifting ring securely fastened inside the hook.

Hook Activated

When the hook is activated, the locking latch is removed and the hook is in the off-load state. When an off-load hook is subject to a load as shown, the hook is unable to rotate and release the lifting ring. This is due to its inherently stable geometry and we therefore say that it is locked by its load. This is what makes our off-load hooks so safe.

Opens Automatically

When the internal release mechanism has been activated and the load applied through the lifting ring to the hook approaches zero, the hook element is able to rotate and release the lifting ring. This means that the hook opens automatically when the boat hits the water but only if the hook has been activated.

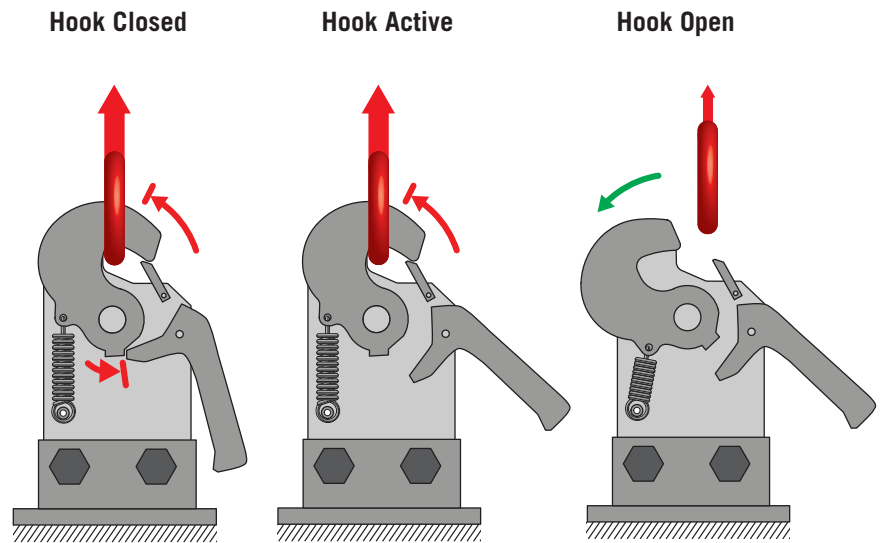

PART OVERVIEW

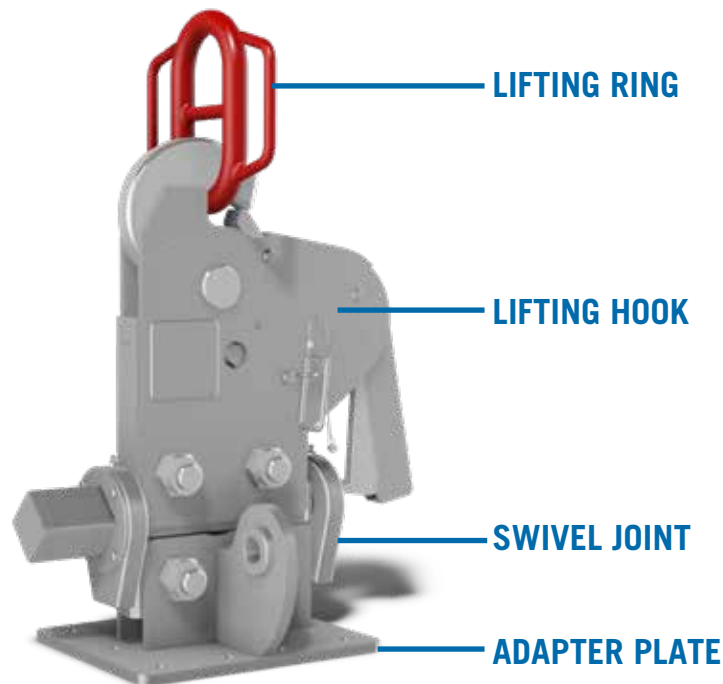

LIFT TYPES

SINGLE POINT

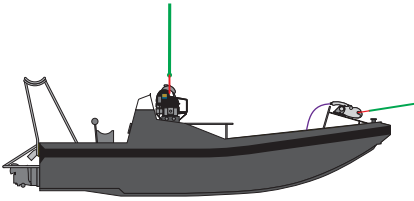

TWIN POINT

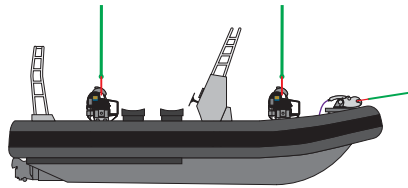

SLINGS (4-POINT)

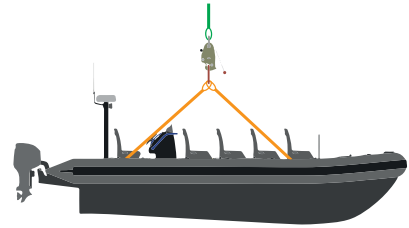

SINGLE POINT LIFT

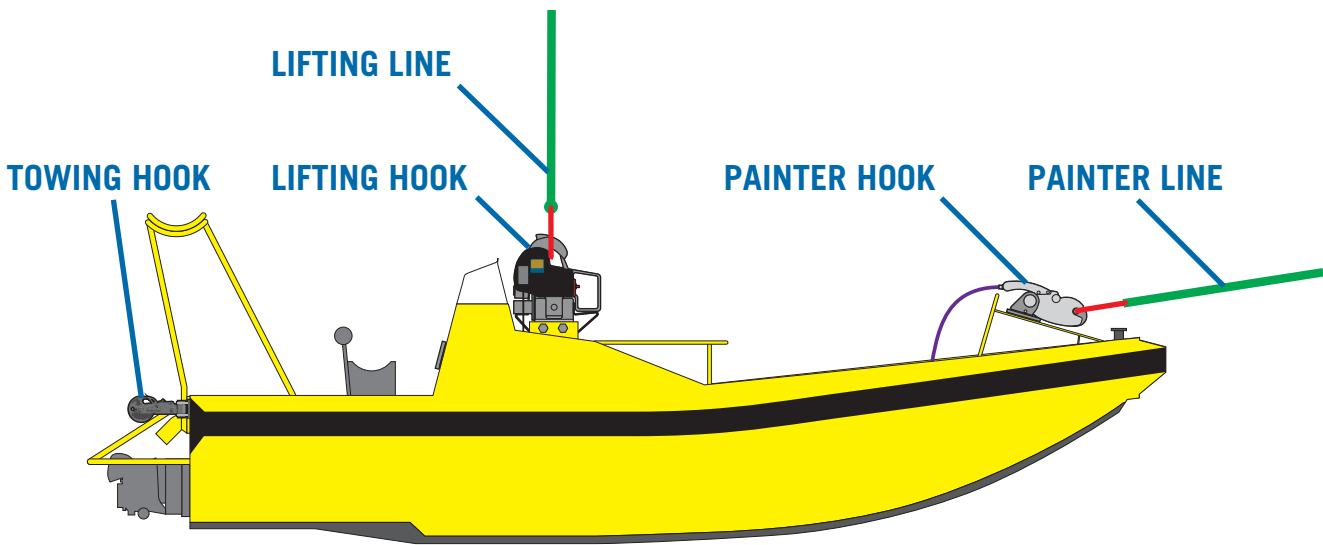

SLINGS (4-POINT) LIFT

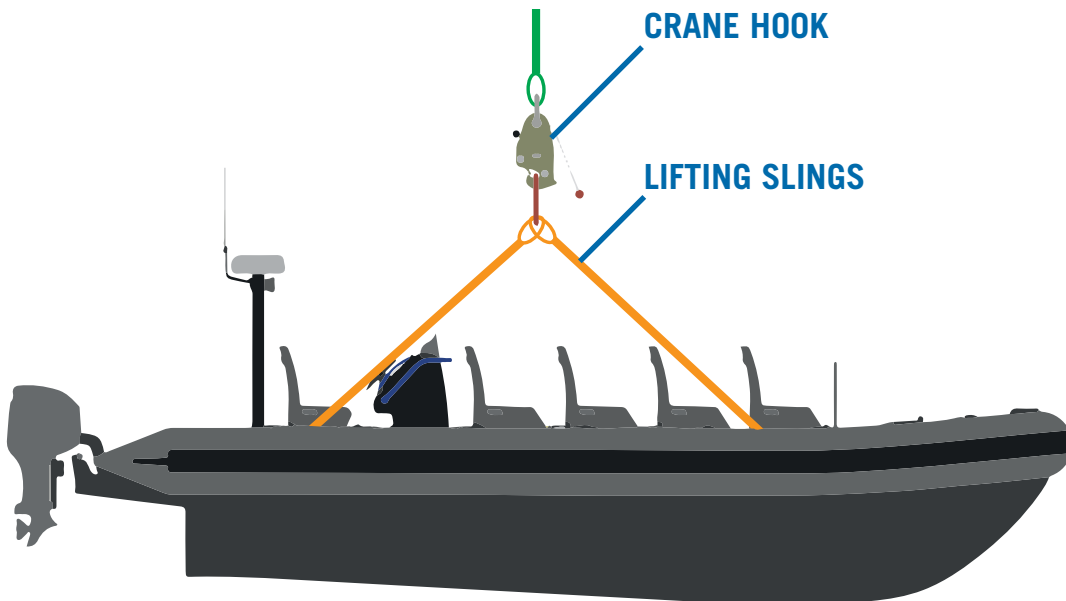

HENRIKSEN HOOKS PRODUCT RANGE

HOOKS
SAFETY QUICK RELEASE HOOKS

Single point lifting arrangement Manual release off-load hooks

HMKG
Manual Release hooks with a safer and less damage-prone design (3,5 / 5 / 8 / 12 / 15)

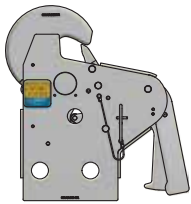

HMKST
Standard Manual Release hooks (3,5 / 5 / 8 / 15)

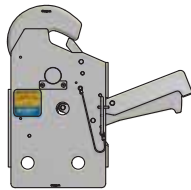

HRH
A small hook for the lighter lifts (1,5)

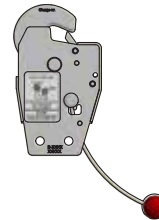

HMKF
Manual Release hooks with foot release (15)

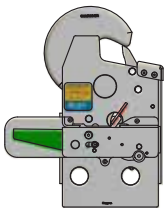

HHSM
Manual release hook with compact design (3,5 / 6 / 12 / 16)

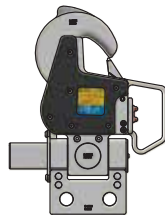

NORHMK
NORSOK R-002 compliant hook with integrated swivel joint (5 / 10 / 15)

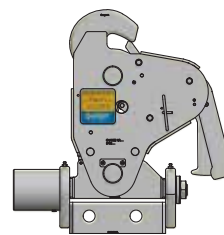

Remote release off-load hooks

HHSR
Electrical remote release hook with compact design (3,5 / 6 / 12 / 16)

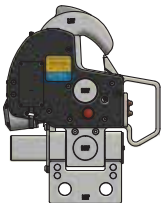

HMKR
Remote release hooks (3,5 / 5 / 8 / 12 / 15)



HMKRW
Remote release hooks with vertical cable entry for swivel joint (5 / 8 / 15)

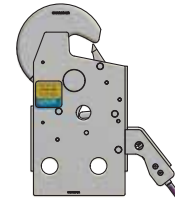

HMKRHF
Remote release hook with front mounted horizontal cable entry (15)

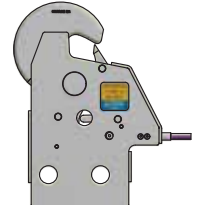

HMKRWH
Remote release hooks with standard handle (3,5 / 5 / 8)

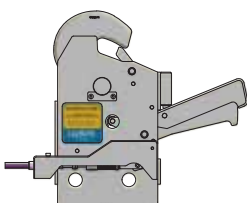

HMKRHB
Remote release hook with horizontal rear mounted cable entry (3,5 / 5 / 8 / 15)

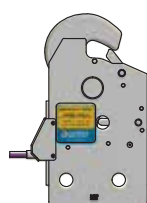

HMKRHI
Remote release hook with hook-integrated IHS (12)

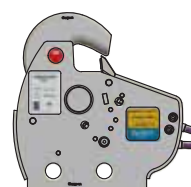

HENRIKSEN HOOKS PRODUCT RANGE

HOOKS
SAFETY QUICK RELEASE HOOKS

Twin Point off-load hook systems

HMKTW
Manual Simultaneous Release Twin System
(7 / 10 / 16 / 30)

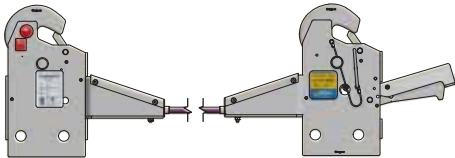

HMKTWE
Electric Simultaneous Release Twin System
(10 / 16 / 24 / 30)



HMKTWV
Remote Simultaneous Release Twin System with vertical cable entry
(7 / 10 / 16 / 30)

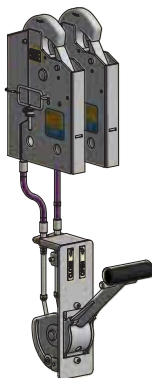

HHSRT
Electric Simultaneous Release Twin System
(24)

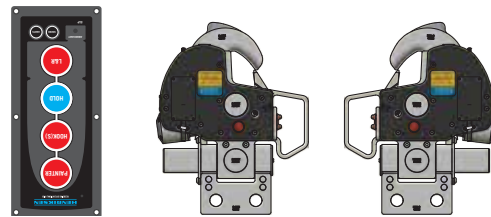

Increased operational awareness systems

LiftView
Realtime visualization and logging of lifting operations



Awarelight
Hook Status Lantern
Liftview add-on / Standalone



Integrated Henriksen System (IHS)

IHS
Electric Integrated Henriksen System
(3,5 / 5 / 8 / 12 / 15)

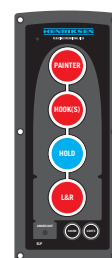

IHS
Manual Integrated Henriksen System
(3,5 / 5 / 8 / 12 / 15)

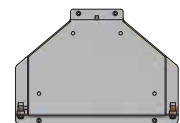

Crane-mounted lifting hooks

HCH
Off-load crane hooks
(1,5 / 3,5 / 6,5 / 10)

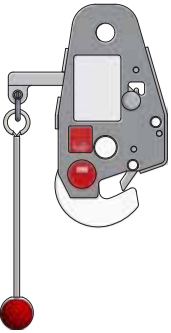

HLH
Liferaft hooks
(1,5 / 3,5)

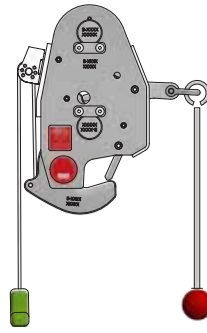

Bow-mounted hooks

HPH
Painter hooks
(2,5 / 5 / 10)



HPHA
Capture claw
(2,5 / 5)

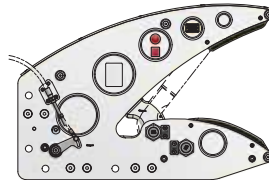

Stern-mounted hooks

HTH
Towing hooks
(2,5 / 5 / 10)

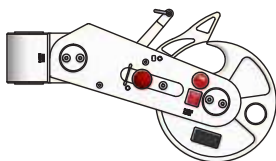

Accessories

Release handle for
HMKR Remote Release Hooks

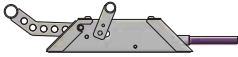

Release handle for
HPH Painter Hooks



ELP
Electric control panel

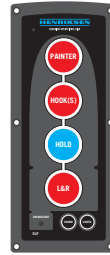

ELA
Electric actuator

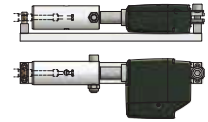

HLR
Lifting rings
(1,5 / 3,5 / 5 / 8 / 12 / 15)



HPR
Painter rings
(2,5 / 5)



Bolts and nuts for all hooks



Shims for all hooks



HSL
Swivel joints
(3,5 / 5 / 8 / 12 / 15)

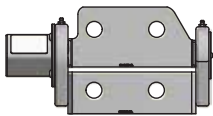

Adapter
(3,5 / 5 / 8 / 12 / 15)

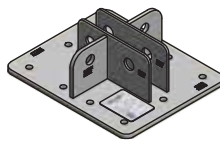

Protection handle for HKMST
Manual Release Hooks

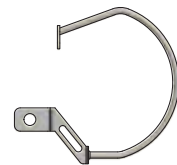

MANUAL OFF-LOAD HOOKS - SAFER HANDLE

HOOKS
SAFETY QUICK RELEASE HOOKS



HMKG 3,5 / 5 / 8 / 12 / 15 HMKGD 3,5 (DUPLEX)

Our safest manual release off-load Hooks. For fast rescue crafts and other types of boats with a single point lifting arrangement.

HOOK	HMKG
RING	HLR
SWIVEL JOINT	HSL

SAFER HANDLE

The HMKG hook type is an evolved version of the original Henriksen HMKST standard hook and displays demonstrable advantages in numerous cases. The improvements are made based on our users input and our extensive experience. The HMKG hooks have a downwards facing handle that eliminates the possibility of the lifting ring catching on the handle (when the hook is mounted properly). The hooks also feature a large lifting ring skid zone which makes inserting the lifting ring much easier. The HMKG hook type is safer and easier to use, and at the same time less exposed to accidental damages and following down time.



OPERATION OF AN OFF-LOAD HOOK

Launch

1. When the boat is being lowered down and is close to the water level, remove the safety pin and release the hook handle.
2. When the boat is waterborne, the hook automatically releases the lifting ring.

Recovery

1. Prepare the hook for recovery by lifting the handle and inserting the safety pin.
2. Grab the lifting ring and connect it by pushing it into the hook.



LIFTING RINGS

We supply Henriksen original lifting rings for all HMK hooks. They are safe and easy to operate with handles that provide a good grip. We strongly recommend the use of our Henriksen lifting rings with our Henriksen hooks as these have geometry that is designed to fit together.



SWIVEL JOINTS

A Swivel joint is mounted between the hook and the lifting frame in order to reduce sideways forces. We recommend installing swivel joints on boats which are frequently used and/or boats that will be launched and recovered in rough sea.

INTEGRATED HENRIKSEN SYSTEM

All Henriksen HMKG hooks can be used in combination with an Integrated Henriksen System (IHS) and a painter hook. We recommend using a IHS system anywhere applicable as it removes the possibility of major operator errors and thereby significantly reduces operational risk.

- All materials used in the Henriksen Hooks are high quality and suitable for marine environment (saltwater proof). The HMKG hooks are made of stainless steel and duplex steel.
- All hooks are delivered in a practical wooden box.

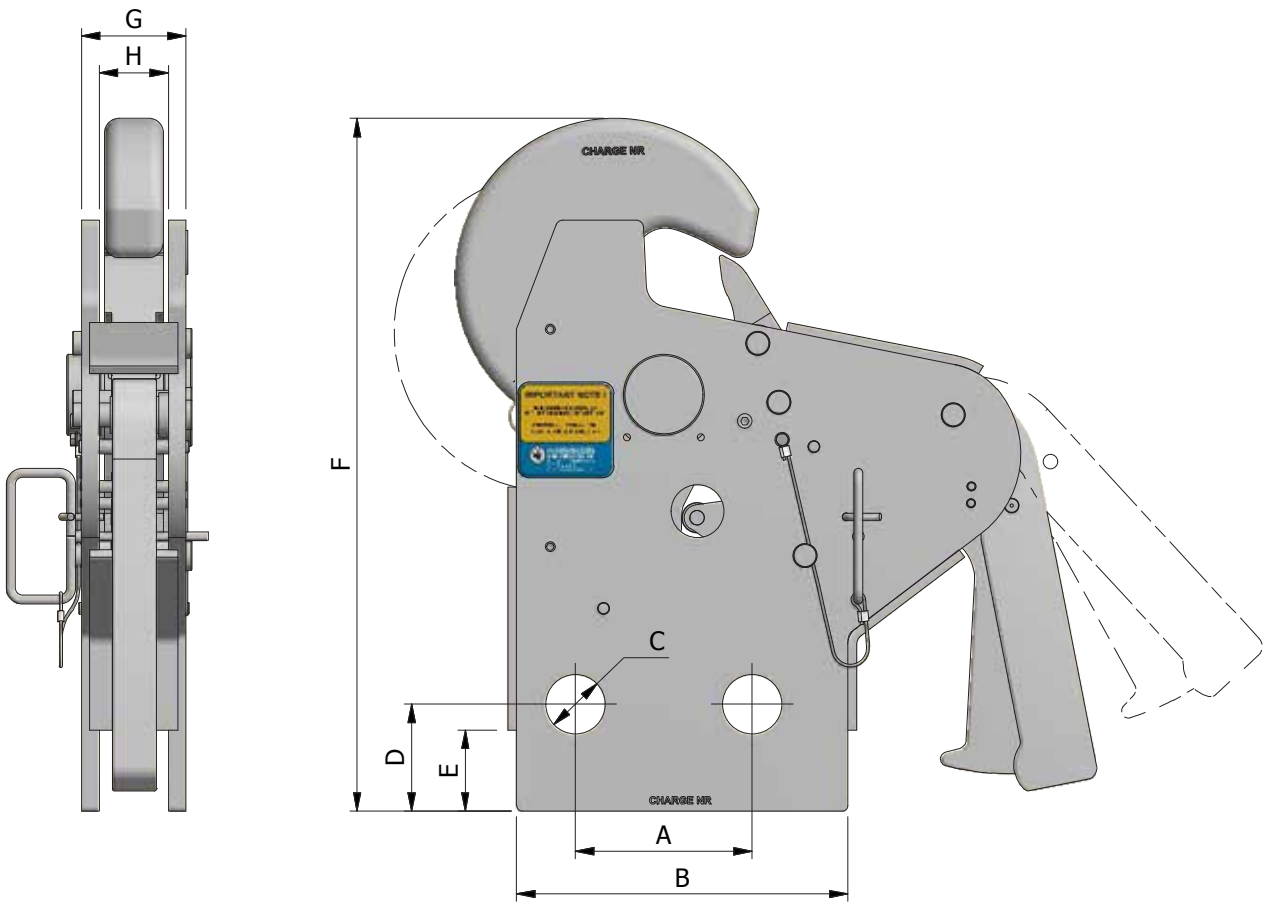

PART NO.	HOOK	SWL	A	B	C	D	E	F	G	H	WEIGHT
HH003050	HMKG 3,5	3 500 kg	100	180	24,5	49	40	352	40	30	11,7 kg
HH003879	HMKGD 3,5	3 500 kg	80	150	24,2	40	37	296	39	29	7,5 kg
HH006180	HMKG 5	5 000 kg	120	225	30,5	60	50	439	47	35	22,1 kg
HH006192	HMKG 8	8 000 kg	120	225	30,5	60	50	439	51	35	25,2 kg
HH000048	HMKG 12	12 000 kg	100	180	30,5	40	0	350	80	50	33,5 kg
HH000050	HMKG 15	15 000 kg	120	225	40,5	73	55	470	71	47	35,4 kg

Materials	High quality stainless steel
Warranty	5 years (When the re-certification and annual inspection is followed)
Documentation	Certificates, Installation-, Operation-, and Maintenance Manual
Packaging	Wooden case
Optional Accessories	<ul style="list-style-type: none"> • Certified bolts and nuts • Henriksen Swivel Joint • Henriksen Lifting Ring • Integrated Henriksen System (IHS)



The HOOKS on this page are all tested and delivered with European Community "MED" CERTIFICATES approved by Det Norske Veritas. They are also approved by Transport Canada (several other certificates are also available on request). Test certificates are based upon IMO / SOLAS.

For more information please visit: www.hhenriksen.com



H. Henriksen AS
 Træleborgveien 15
 3112 Tjønsberg
 Phone: 333 78 400
 Mail: hooks@hhenriksen.com

MANUAL OFF-LOAD HOOKS - ORIGINAL

HOOKS
SAFETY QUICK RELEASE HOOKS



HMKST 3,5 / 5 / 8 / 15

For fast rescue crafts and other types of boats with a single point lifting arrangement.

HOOK	HMKST
RING	HLR
SWIVEL JOINT	HSL

ORIGINAL

The HMKST hooks are the original Henriksen developed quick release, off-load lifting hooks. For decades this product has proven to be the most reliable, best and safest launch and recovery lifting hook on the maritime market, and still continues to live up to its reputation. Available as an accessory is the HMKST release handle protection bar. This gives the handle additional protection as well as a hand rail for the operator to hold on to during operations in rough conditions.



OPERATION OF A HENRIKSEN OFF-LOAD HOOK

Launch

1. When the boat is being lowered down and is close to the water level, remove the safety pin and release the hook handle.
2. When the boat is waterborne, the hook automatically releases the lifting ring.

Recovery

1. Prepare the hook for recovery by lifting the handle and inserting the safety pin.
2. Grab the lifting ring and connect it by pushing it into the hook.



LIFTING RINGS

We supply Henriksen original lifting rings for all HMK hooks. They are safe and easy to operate with handles that provide a good grip. We strongly recommend the use of our Henriksen lifting rings with our Henriksen hooks as these have geometry that is designed to fit together.



SWIVEL JOINTS

A Swivel joint is mounted between the hook and the lifting frame in order to reduce sideways forces. We recommend installing swivel joints on boats which are frequently used and/or boats that will be launched and recovered in rough sea.

INTEGRATED HENRIKSEN SYSTEM

All Henriksen HMKST hooks can be used in combination with an Integrated Henriksen System (IHS) and a painter hook. We recommend using a IHS system anywhere applicable as it removes the possibility of major operator errors and thereby significantly reduces operational risk.

- All materials used in the Henriksen Hooks are high quality and suitable for marine environment (saltwater proof). The HMKST hooks are made of stainless steel and duplex steel.
- All Hooks are delivered in a practical wooden box.

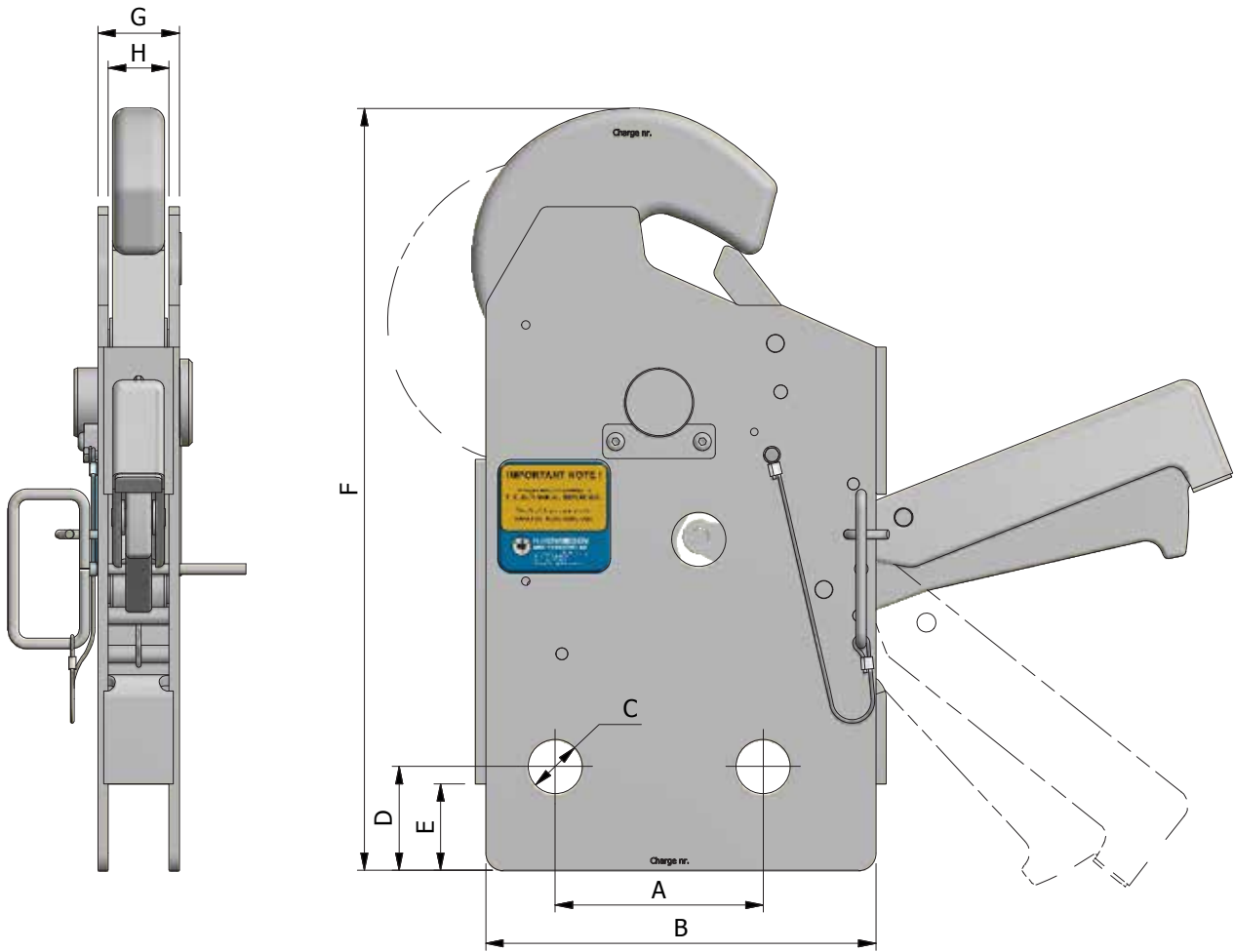

PART NO.	HOOK	SWL	A	B	C	D	E	F	G	H	WEIGHT
HH000026	HMKST 3,5	3 500 kg	100	180	24,5	49	40	352	40	30	9,9 kg
HH000027	HMKST 5	5 000 kg	120	225	30,5	60	50	440	47	35	18,1 kg
HH000028	HMKST 8	8 000 kg	120	225	30,5	60	50	440	51	35	20,3 kg
HH000034	HMKST 15	15 000 kg	120	225	40,5	73	55	470	74	47	30,9 kg

Materials	High quality stainless steel
Warranty	5 years (When the re-certification and annual inspection is followed)
Documentation	Certificates, Installation-, Operation-, and Maintenance Manual
Packaging	Wooden case
Optional Accessories	<ul style="list-style-type: none"> • Certified bolts and nuts • Henriksen Swivel Joint • Henriksen Lifting Ring • Protection Handle • Integrated Henriksen System (IHS)



The HOOKS on this page are all tested and delivered with European Community "MED" CERTIFICATES approved by Det Norske Veritas. They are also approved by Transport Canada (several other certificates are also available on request). Test certificates are based upon IMO / SOLAS.

For more information please visit: www.hhenriksen.com



H. Henriksen AS
 Træleborgveien 15
 3112 Tjønsberg
 Phone: 333 78 400
 Mail: hooks@hhenriksen.com

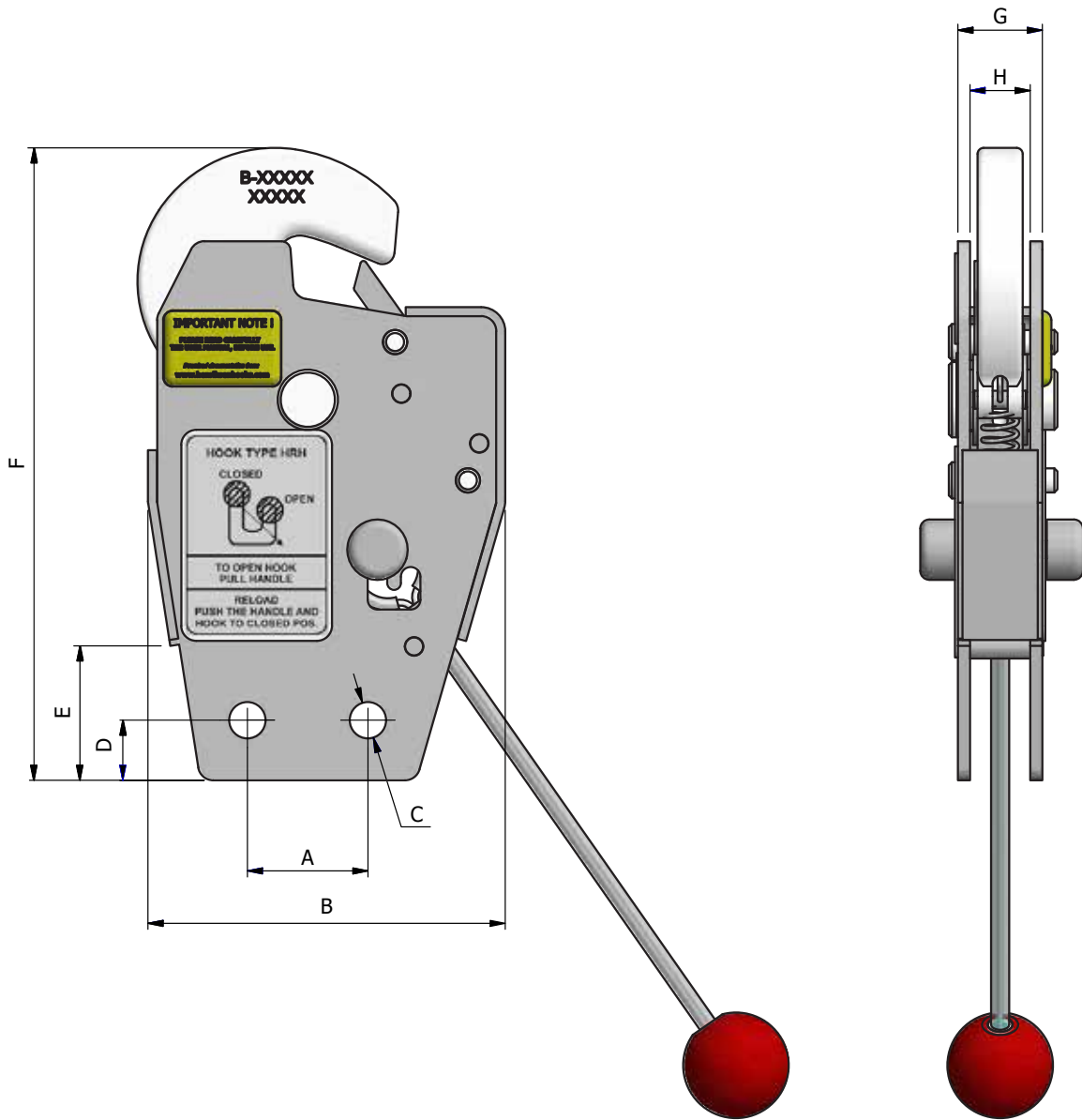

PART NO.	HOOK	SWL	A	B	C	D	E	F	G	H	WEIGHT
HH000033	HRH 1,5	1 650 kg	40	119	ø12	20	45	210	28	20	2,27 kg

Materials	High quality stainless steel
Warranty	5 years (When the re-certification and annual inspection is followed)
Documentation	Certificates, Installation-, Operation-, and Maintenance Manual
Packaging	Wooden case
Optional Accessories	<ul style="list-style-type: none"> • Certified bolts and nuts • Henriksen Swivel Joint • Henriksen Lifting Ring • Integrated Henriksen System (IHS)



The HOOKS on this page are all tested and delivered with European Community "MED" CERTIFICATES approved by Det Norske Veritas. They are also approved by Transport Canada (several other certificates are also available on request). Test certificates are based upon IMO / SOLAS.



H. Henriksen AS
 Træleborgveien 15
 3112 Tjønsberg
 Phone: 333 78 400
 Mail: hooks@henriksen.com

For more information please visit: www.henriksen.com

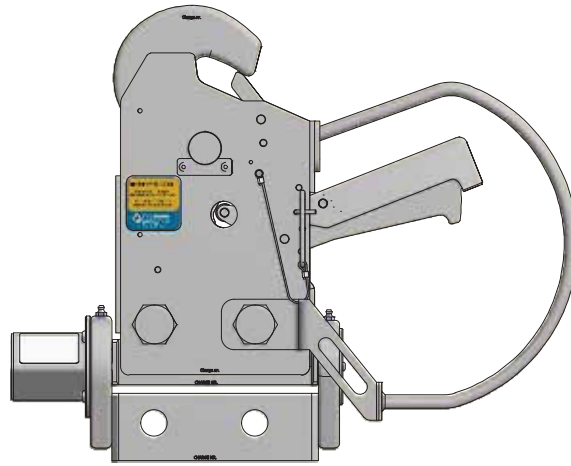

The protection handle will protect the release handle from getting damaged. The protection handle fits over the HSL swivel joint and allows it to move freely.

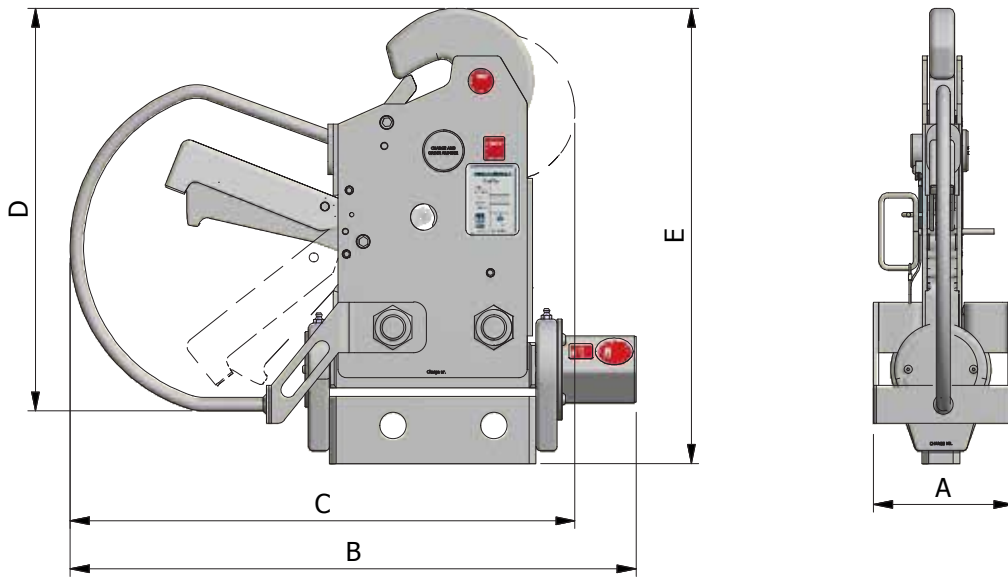

PART NO.	FITS	A	B	C	D	E	WEIGHT
HH000025	HMKST 3,5	136	557	498	371	435	1,8 kg
HH000073	HMKST 5 & 8	166	674	601	479	541	2,8 kg
HH003062	HMKST 15	189	677	627	479	569	2,8 kg

MANUAL OFF-LOAD HOOKS - COMPACT

HOOKS
SAFETY QUICK RELEASE HOOKS

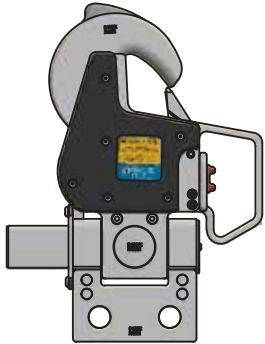

HHSM 3,5 / 6 / 12 / 16

Latest generation off-load hooks with integrated swivel joint with a more compact size and lower weight.

HOOK	HHSM
RING	HLR
SWIVEL JOINT	-

COMPACT

The HHSM Manual hooks is the latest generation Henriksen Hooks. They have been designed with integrated swivel joint which makes them lighter and more compact compared to using a conventional hook and swivel joint combination. The HHSM hooks are activated using the compact activation handle that sits within the combined hand grip and ring guide rail. When the boat is close to the water the hook operator activates the hook using the handle and enables the activation handle toggle. When the boat is waterborne and the load is removed the hook automatically opens.



Using a swivel joint allows the lifting arrangement to pivot and reduces the risk for a lot of potential unwanted loads. We always recommend using a swivel, especially for boats that are frequently used.

OPERATION OF A HENRIKSEN REMOTE RELEASE OFF-LOAD HOOK

Launch

1. When the boat is being lowered down, is clear off all obstacles and close to the water level, use the activation handle and toggle to activate the hook release mechanism. When the boat is waterborne, the hook automatically releases the lifting ring.

Recovery

1. Prepare the hook for recovery by closing the hook and making sure the handle lock is in bottom position.
2. Grab the lifting ring and connect it by pushing it into the hook.



LIFTING RINGS

We supply Henriksen original lifting rings for all Henriksen hooks. They are safe and easy to operate with handles that provide a good grip. We strongly recommend the use of our Henriksen lifting rings with our Henriksen hooks as these have geometry that is designed to fit together.

INTEGRATED HENRIKSEN SYSTEM

See the remote activated version (HHSR) for a similar hook that can be used together with a painter hook in a Integrated Henriksen System (IHS). We recommend using a IHS system anywhere applicable as it removes the possibility of certain major operator errors and thereby significantly reduces operational risk.

- All materials used in the Henriksen Hooks are high quality, corrosion resistant, and suitable for marine environment (saltwater proof).
- All hooks are delivered in a practical wooden box.

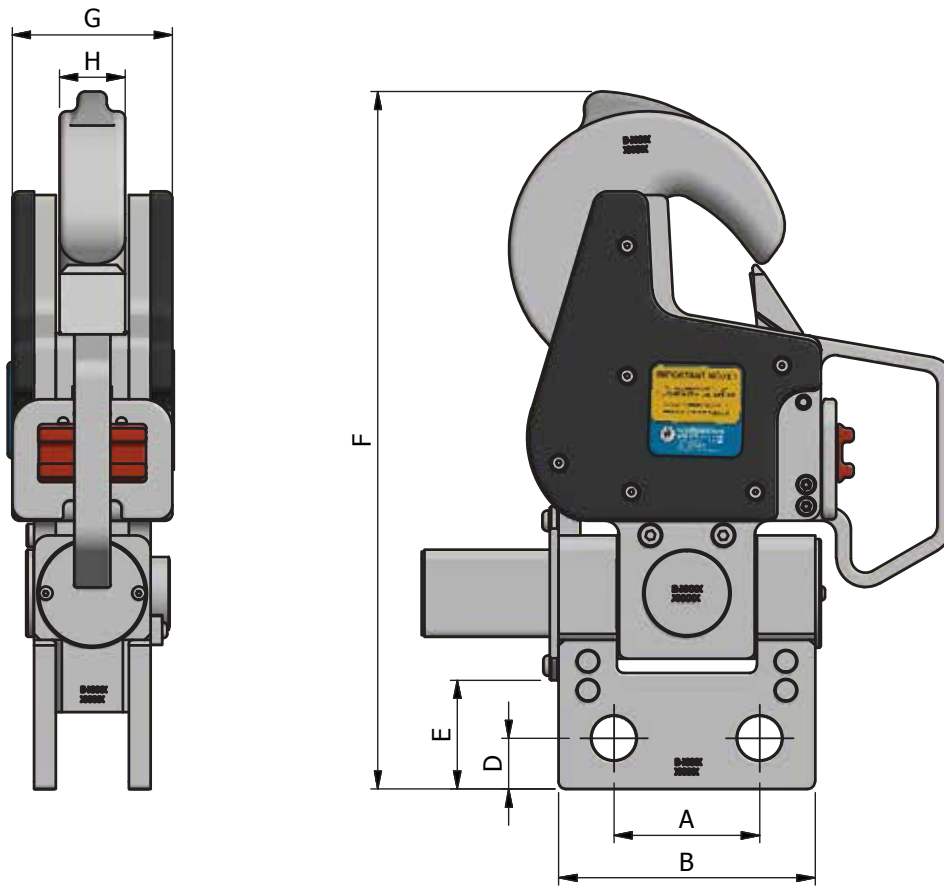

PART NO.	HOOK	SWL	A	B	C	D	E	F	G	H	WEIGHT
-	HHSM 3,5	-	-	-	-	-	-	-	-	-	-
-	HHSM 6	-	-	-	-	-	-	-	-	-	-
HH000135	HHSM 12	12 000 kg	100	176	30,5	35	75	482	110	45	38,5 kg
-	HHSM 16	-	-	-	-	-	-	-	-	-	-

Materials	High quality stainless steel
Warranty	5 years (When the re-certification and annual inspection is followed)
Documentation	Certificates, Installation-, Operation-, and Maintenance Manual
Packaging	Wooden case
Optional Accessories	<ul style="list-style-type: none"> • Certified bolts and nuts • Henriksen Lifting Ring • Integrated Henriksen System (IHS)



The HOOKS on this page are all tested and delivered with European Community "MED" CERTIFICATES approved by Det Norske Veritas. They are also approved by Transport Canada (several other certificates are also available on request). Test certificates are based upon IMO / SOLAS.



H. Henriksen AS
 Træleborgveien 15
 3112 Tjønsberg
 Phone: 333 78 400
 Mail: hooks@hhenriksen.com

For more information please visit: www.hhenriksen.com

REMOTE RELEASE HOOKS - ELECTRICAL

HOOKS
SAFETY QUICK RELEASE HOOKS

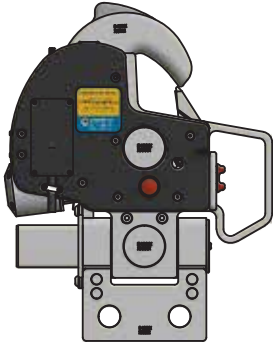

HHSR 3,5 / 6 / 12 / 16
Latest generation Henriksen remote release off-load hooks. Electric remote actuation with the ELP control panel. IP67 protection.

HOOK	HHSR
RING	HLR
SWIVEL JOINT	HSL

COMPACT

The HHSR Remote hooks is the newest generation Henriksen Hooks. They have been designed with integrated swivel joint, which makes them lighter and more compact. They have an electric solenoid actuator, and goes with the ELP control panel which makes lifting operations intuitive and easy. Remote release hooks have the same operational principles as manual release hooks: when the boat is close to the water the boat operator primes the hook for release using the control panel. When the boat is waterborne and the load is removed the hook automatically opens. The big safety advantage of remote release hooks is that no operator is needed near the hook in the launch sequence.



HENRIKSEN HOOK WITH SWIVEL AND REMOTE RELEASE

The HHSR Hooks are delivered with ELP Control panel and wires. An optional painter hook with actuator can also be added for a complete electric IHS system with fast and easy pushbutton action.

OPERATION OF A HENRIKSEN REMOTE RELEASE OFF-LOAD HOOK

Launch

1. When the boat is being lowered down, is clear off all obstacles and close to the water level, use the control panel to activate the hook release mechanism. When the boat is waterborne, the hook automatically releases the lifting ring.

Recovery

1. Prepare the hook for recovery by closing the hook and making sure the handle lock is in bottom position.
2. Grab the lifting ring and connect it by pushing it into the hook.



LIFTING RINGS

We supply Henriksen original lifting rings for all Henriksen hooks. They are safe and easy to operate with handles that provide a good grip. We strongly recommend the use of our Henriksen lifting rings with our Henriksen hooks as these have geometry that is designed to fit together.

INTEGRATED HENRIKSEN SYSTEM

All Henriksen HHSR hooks can be used in combination with an Integrated Henriksen System (IHS) and a painter hook. We recommend using a IHS system anywhere applicable as it removes the possibility of certain major operator errors and thereby significantly reduces operational risk.

- All materials used in the Henriksen Hooks are high quality and suitable for marine environment (saltwater proof).
- All hooks are delivered in a practical wooden box.

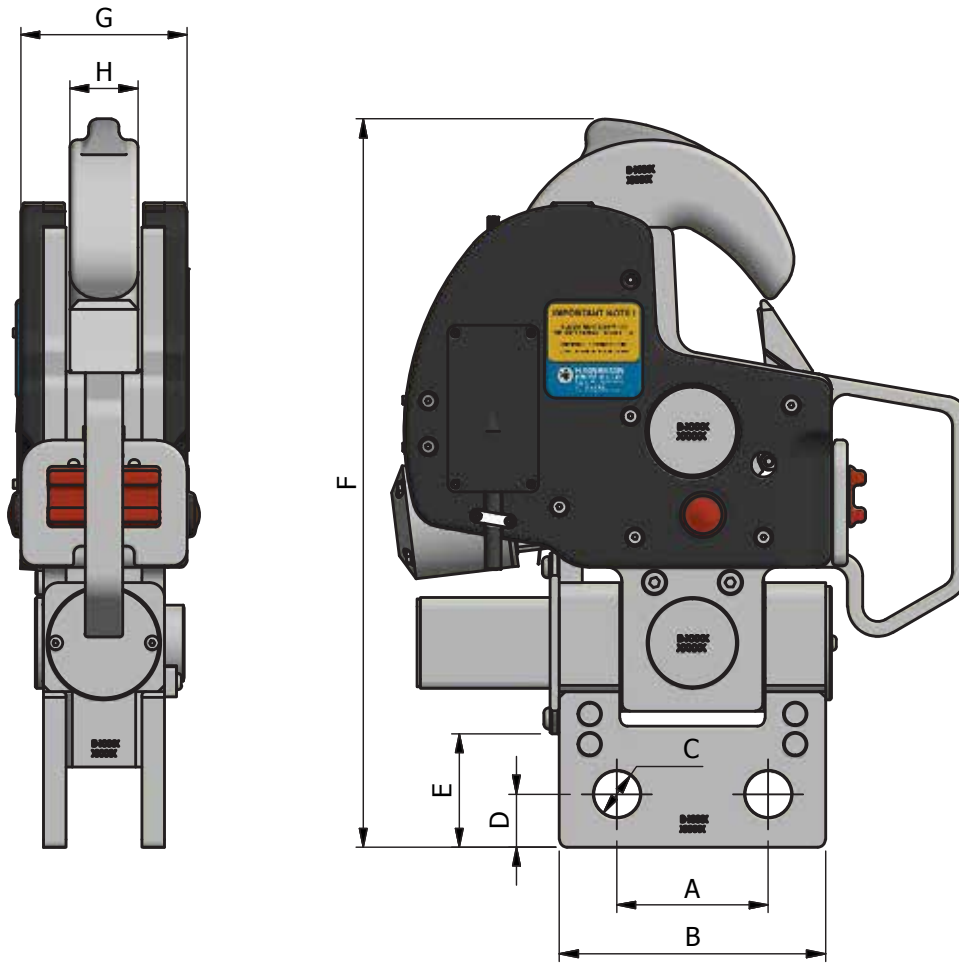

PART NO.	HOOK	SWL	A	B	C	D	E	F	G	H	WEIGHT
-		3 500 kg	-	-	-	-	-	-	-	-	-
-		6 000 kg	-	-	-	-	-	-	-	-	-
HH000129	HHSR 12	12 000 kg	100	176	30,5	35	75	482	110	45	41,5 kg
-		16 000 kg	-	-	-	-	-	-	-	-	-

Materials	High quality stainless steel
Warranty	5 years (When the re-certification and annual inspection is followed)
Documentation	Certificates, Installation-, Operation-, and Maintenance Manual
Packaging	Wooden case
Optional Accessories	<ul style="list-style-type: none"> • Certified bolts and nuts • Henriksen Lifting Ring • Integrated Henriksen System (IHS)



The HOOKS on this page are all tested and delivered with European Community "MED" CERTIFICATES approved by Det Norske Veritas. They are also approved by Transport Canada (several other certificates are also available on request). Test certificates are based upon IMO / SOLAS.

For more information please visit: www.hhenriksen.com



H. Henriksen AS
 Træleborgveien 15
 3112 Tjønsberg
 Phone: 333 78 400
 Mail: hooks@hhenriksen.com

ELP - ELECTRIC CONTROL PANEL

The control panel has been developed for use with the HHSR Remote release hooks and one panel handles up to two hooks and a painter hook in a twin IHS system. The panel receives signals from sensors integrated in the hook and displays the corresponding awarelight status on the panel.

The panel has a green backlight for use at night that is auto-dimmed by day, dimmable in 5 steps as well as completely off for low visibility operations. It also features a (mutable) buzzer that can provide the awarelight signals as sound signals, and thereby providing information even without having to take a look.

The panel is prepared for wireless applications and programmable, and is therefore also perfect for uses in USV and other concepts.

EASY ASSEMBLY AND INSTALLATION

The ELP and all its components are IP67 compatible (when connected) and will therefore be able to withstand complete submersion to 1 meter in 30 min no matter where it is mounted in the boat.

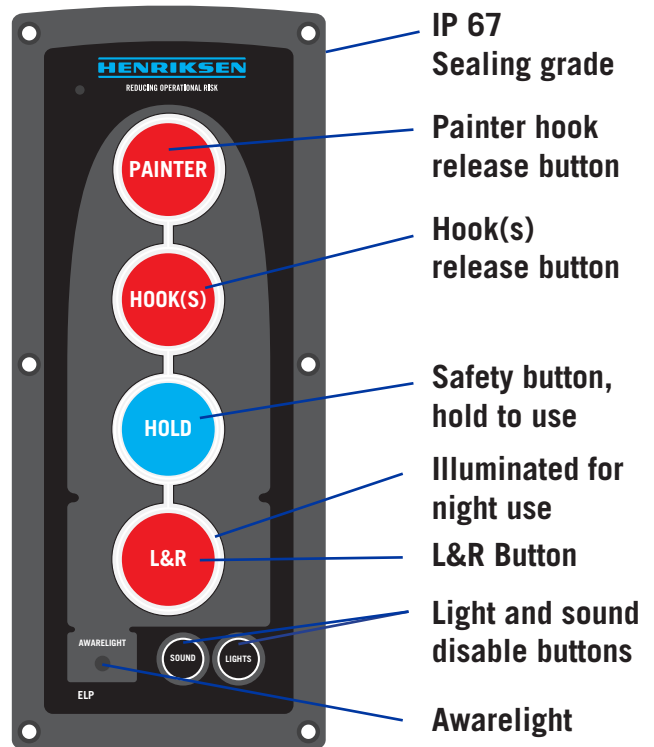

OPERATION

Launch

1. The HOLD button is a safety feature and has to be held down in order to use any of the red buttons on the panel. When the boat is being lowered down, is clear off all obstacles and close to the water level, press the HOOK(S) button to activate the hook and observe the awarelight lamp change signal to ACTIVATED. When the boat is waterborne, the hook automatically releases the lifting ring and it is now possible to release the painter hook.
2. Press the PAINTER-button to release the painter line

Recovery

1. Prepare the hook for recovery by returning the hook to closed position.
2. Grab the lifting ring and connect it by pushing it into the hook.
3. Push the L&R Button on the control panel, or on the hook.

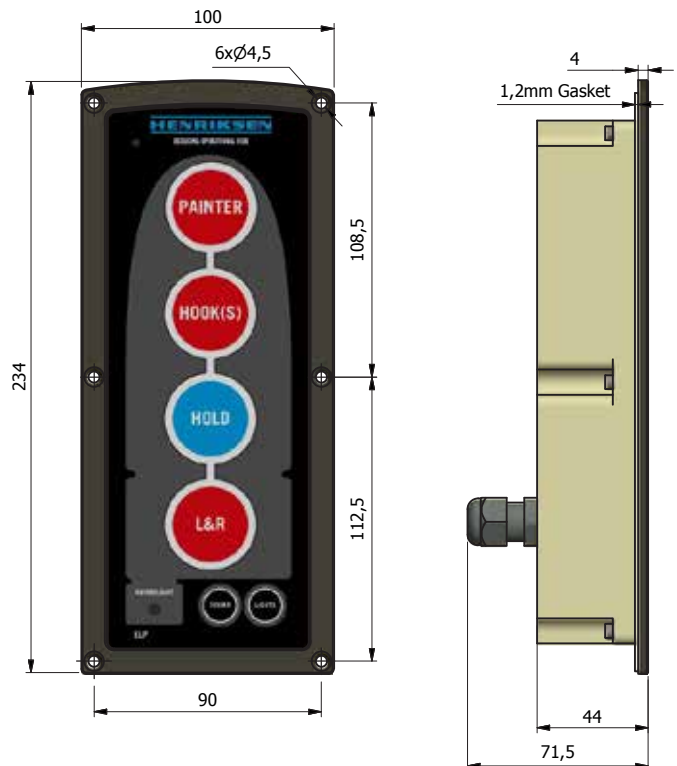

The HOOKS on this page are all tested and delivered with European Community "MED" CERTIFICATES approved by Det Norske Veritas. They are also approved by Transport Canada (several other certificates are also available on request). Test certificates are based upon IMO / SOLAS.

For more information please visit: www.hhenriksen.com



H. Henriksen AS
 Træleborgveien 15
 3112 Tjønsberg
 Phone: 333 78 400
 Mail: hooks@hhenriksen.com

REMOTE RELEASE HOOKS - MECHANICAL

HOOKS
SAFETY QUICK RELEASE HOOKS



HMKR 3,5 / 5 / 8 / 12 / 15

HMKRW 5 / 8 / 15

HMKRWH 3,5 / 5 / 8

HMKRHB 3,5 / 5 / 8 / 15

HMKRHI 12

HMKRHF 15

For fast rescue crafts and other types of boats with a single point lifting arrangement

HOOK	HMKR
RING	HLR
SWIVEL	HSL
JOINT	

MECHANICAL REMOTE RELEASE

The HMKR HOOKS are remotely operated hooks where the remote control handle can be placed close to the helmsman's position. It works in the same way as the manually operated off-load hooks. Remote release hooks have the same operational principles as manual release hooks: when the boat is close to the water the boat operator primes the hook for release using the remote handle. When the boat is waterborne and the load is removed the hook automatically opens. The big safety advantage of the HMKR hooks is that no operator is needed near the hook in the launch sequence.



HENRIKSEN REMOTE RELEASE HOOKS

The Standard Remote Release Hooks are delivered with a push/pull cable directly connected to the remote handle. Alternatively, we can provide an electrical or pneumatic system where this is required.

OPERATION OF A HENRIKSEN REMOTE RELEASE OFFLOAD HOOK

Launch

1. When the boat is being lowered down, is clear off all obstacles and close to the water level, use the remote handle to activate the hook release mechanism. When the boat is waterborne, the hook automatically releases the lifting ring.

Recovery

1. Prepare the hook for recovery by lifting the handle and inserting the safety pin.
2. Grab the lifting ring and connect it by pushing it into the hook.



LIFTING RINGS

We supply Henriksen original lifting rings for all Henriksen hooks. They are safe and easy to operate with handles that provide a good grip. We strongly recommend the use of our Henriksen lifting rings with our Henriksen hooks as these have geometry that is designed to fit together.



SWIVEL JOINTS

A Swivel joint is mounted between the hook and the lifting frame in order to reduce sideway forces. We recommend installing swivel joints on boats which are frequently used and/or boats that will be launched and recovered in rough sea.

INTEGRATED HENRIKSEN SYSTEM

All Henriksen HMKR hooks can be used in combination with an Integrated Henriksen System (IHS) and a painter hook. We recommend using a IHS system anywhere applicable as it removes the possibility of certain major operator errors and thereby significantly reduces operational risk.

- All materials used in the Henriksen Hooks are high quality and suitable for marine environment (saltwater proof). The HMKR Hooks are made of stainless steel and duplex steel.
- All hooks are delivered in a practical wooden box.

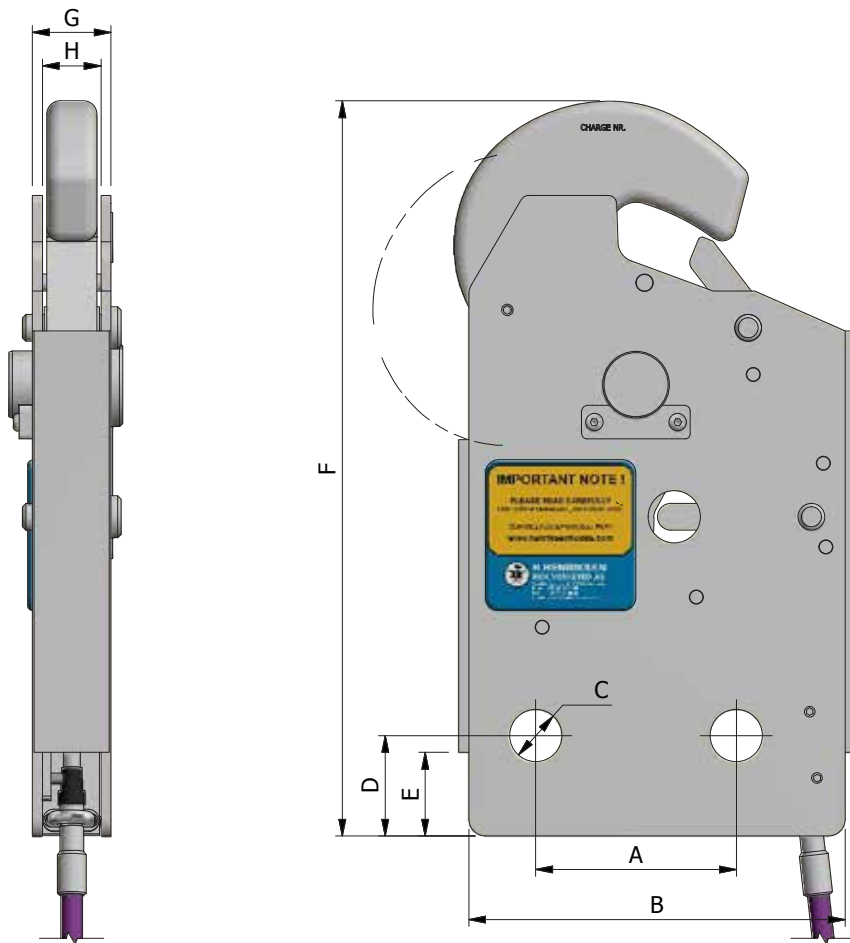

PART NO.	HOOK	SWL	A	B	C	D	E	F	G	H	WEIGHT
HH000115	HMKR 3,5	3 500 kg	100	185	24,5	49	40	352	40	30	10,1 kg
HH000107	HMKR 5	5 000 kg	120	225	30,5	60	50	439	47	35	17,3 kg
HH000087	HMKR 8	8 000 kg	120	225	30,5	60	50	439	51	35	19,4 kg
HH000077	HMKR 12	12 000 kg	100	226	30,5	40	50	350	80	50	22,9 kg
HH000091	HMKR 15	15 000 kg	120	225	40,5	73	50	470	71	47	30,4 kg

Materials	High quality stainless steel
Warranty	5 years (When the re-certification and annual inspection is followed)
Documentation	Certificates, Installation-, Operation-, and Maintenance Manual
Packaging	Wooden case
Optional Accessories	<ul style="list-style-type: none"> • Certified bolts and nuts • Henriksen Swivel Joint • Henriksen Lifting Ring • Integrated Henriksen System (IHS)



The HOOKS on this page are all tested and delivered with European Community "MED" CERTIFICATES approved by Det Norske Veritas. They are also approved by Transport Canada (several other certificates are also available on request). Test certificates are based upon IMO / SOLAS.



H. Henriksen AS
 Træleborgveien 15
 3112 Tjønsberg
 Phone: 333 78 400
 Mail: hooks@hhenriksen.com

For more information please visit: www.hhenriksen.com

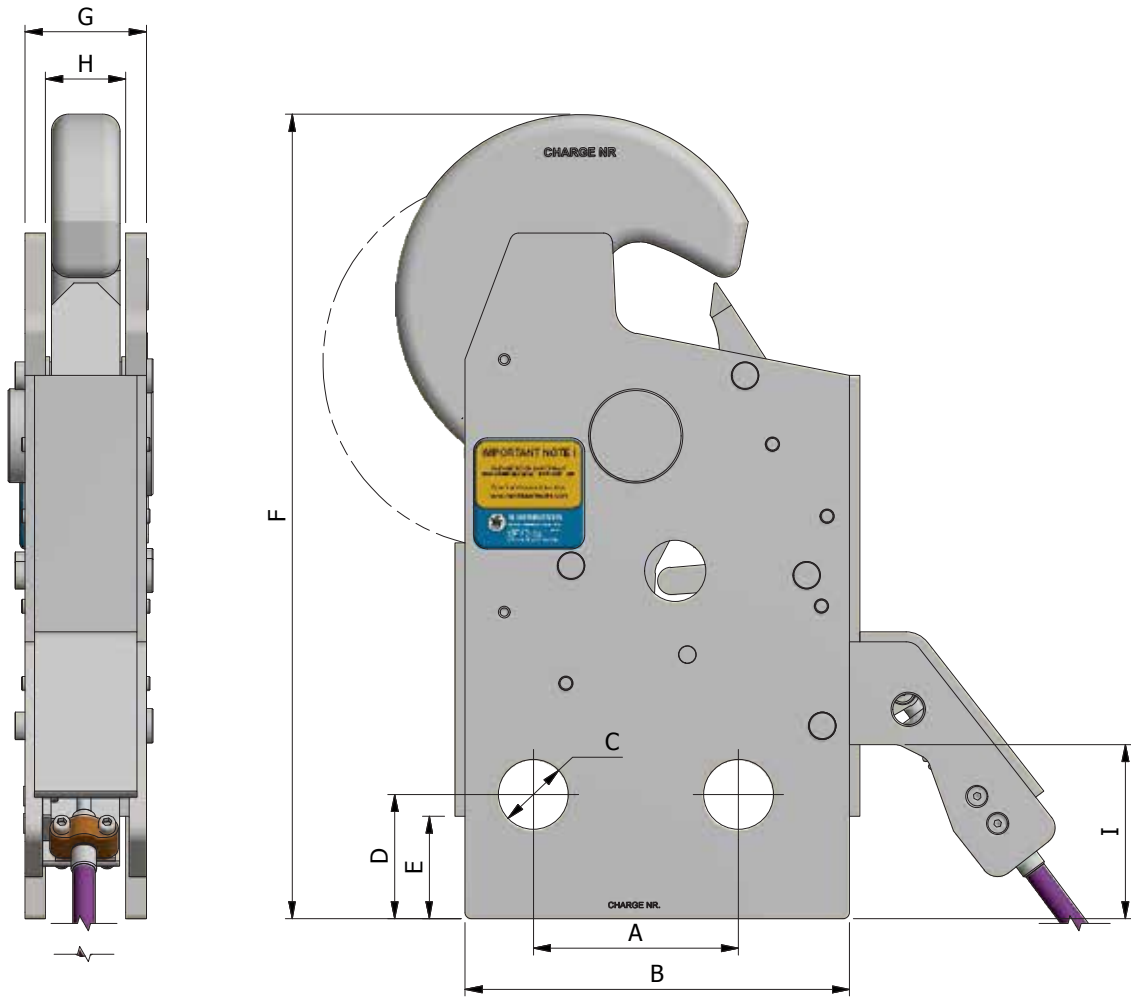

PART NO.	HOOK	SWL	A	B	C	D	E	F	G	H	I	WEIGHT
HH000108	HMCRW 5	5 000 kg	120	225	30,5	60	50	467	47	35	92	18,9 kg
HH000085	HMCRW 8	8 000 kg	120	225	30,5	60	50	467	51	35	92	20,9 kg
HH000105	HMCRW 15	15 000 kg	120	225	40,5	73	60	470	71	47	102	31,6 kg

Materials	High quality stainless steel
Warranty	5 years (When the re-certification and annual inspection is followed)
Documentation	Certificates, Installation-, Operation-, and Maintenance Manual
Packaging	Wooden case
Optional Accessories	<ul style="list-style-type: none"> • Certified bolts and nuts • Henriksen Swivel Joint • Henriksen Lifting Ring • Integrated Henriksen System (IHS)



The HOOKS on this page are all tested and delivered with European Community "MED" CERTIFICATES approved by Det Norske Veritas. They are also approved by Transport Canada (several other certificates are also available on request). Test certificates are based upon IMO / SOLAS.

For more information please visit: www.hhenriksen.com



H. Henriksen AS
 Træleborgveien 15
 3112 Tjønsberg
 Phone: 333 78 400
 Mail: hooks@hhenriksen.com

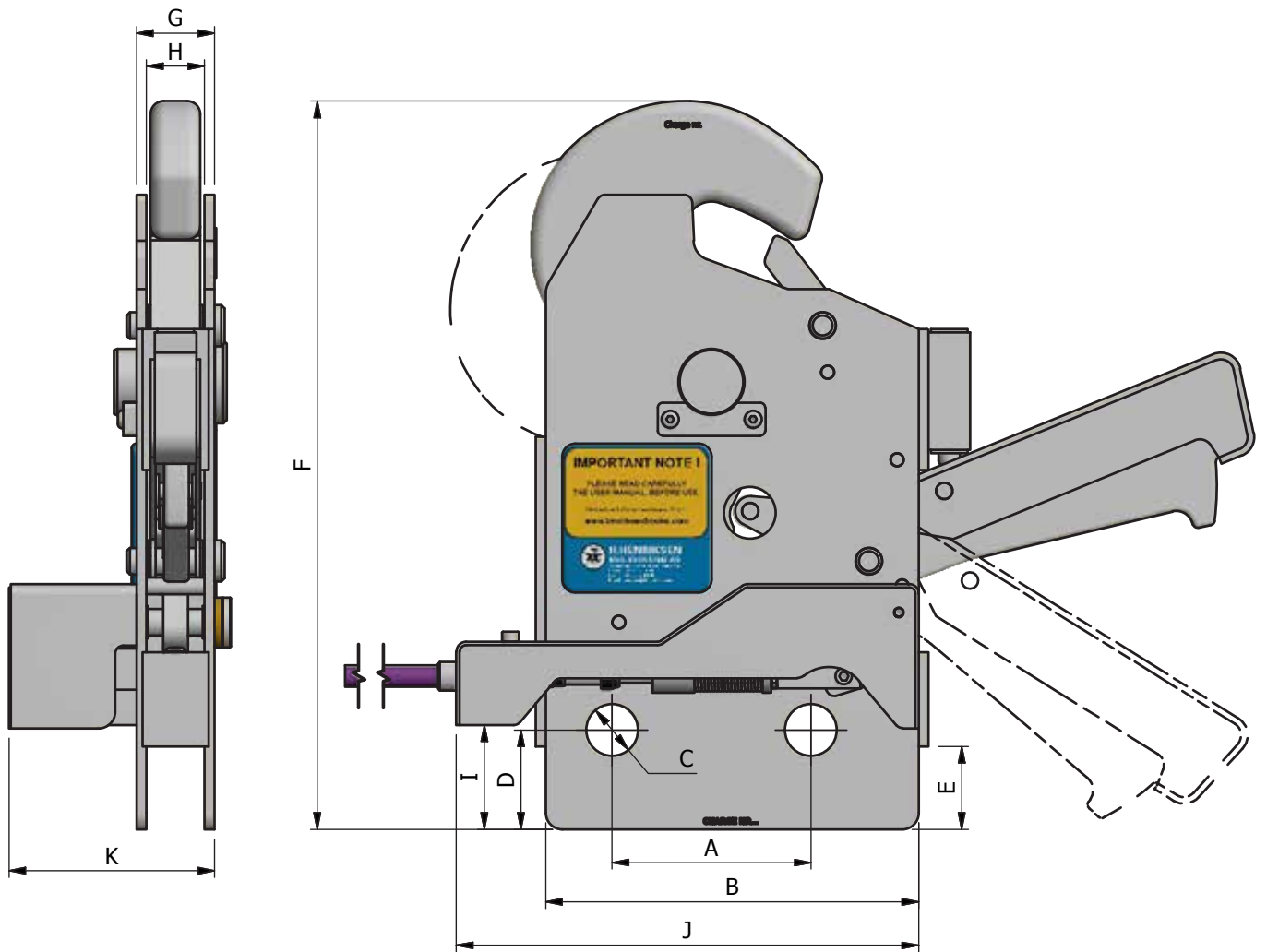

PART NO.	HOOK	SWL	A	B	C	D	E	F	G	H	I	J	K	WEIGHT
HH000709	HMKRWH 3,5	3 500 kg	100	180	24,5	49	40	352	40	30	20	367	97	10,1 kg
HH000686	HMKRWH 5	5 000 kg	120	225	30,5	60	50	440	47	35	63	289	124	22,5 kg
HH002200	HMKRWH 8	8 000 kg	120	225	30,5	60	50	459	51	35	63	279	128	25,5 kg

Materials	High quality stainless steel
Warranty	5 years (When the re-certification and annual inspection is followed)
Documentation	Certificates, Installation-, Operation-, and Maintenance Manual
Packaging	Wooden case
Optional Accessories	<ul style="list-style-type: none"> • Certified bolts and nuts • Henriksen Swivel Joint • Henriksen Lifting Ring • Integrated Henriksen System (IHS)



The HOOKS on this page are all tested and delivered with European Community "MED" CERTIFICATES approved by Det Norske Veritas. They are also approved by Transport Canada (several other certificates are also available on request). Test certificates are based upon IMO / SOLAS.

For more information please visit: www.hhenriksen.com



H. Henriksen AS
 Træleborgveien 15
 3112 Tjønsberg
 Phone: 333 78 400
 Mail: hooks@hhenriksen.com

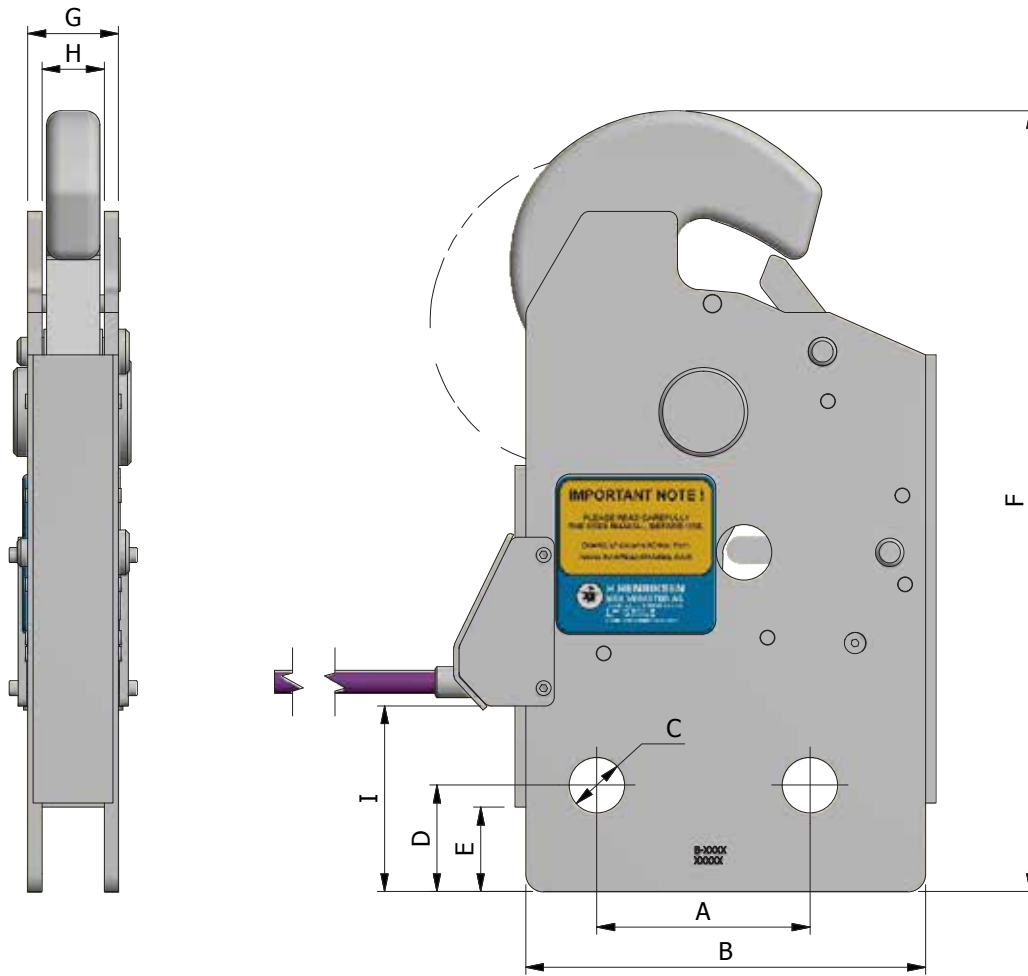

PART NO.	HOOK	SWL	A	B	C	D	E	F	G	H	I	WEIGHT
HH000088	HMKRHB 3,5	3 500 kg	100	180	24,5	49	40	352	40	30	90	10,1 kg
HH005139	HMKRHB 5	5 000 kg	120	225	30,5	60	50	440	47	35	113	16,8 kg
HH007652	HMKRHB 8	8 000 kg	120	225	30,5	60	48	440	51	35	105	19,8 kg
HH007576	HMKRHB 15	15 000 kg	120	225	40,5	73	50	470	71	47	220	30,0 kg

Materials	High quality stainless steel
Warranty	5 years (When the re-certification and annual inspection is followed)
Documentation	Certificates, Installation-, Operation-, and Maintenance Manual
Packaging	Wooden case
Optional Accessories	<ul style="list-style-type: none"> • Certified bolts and nuts • Henriksen Swivel Joint • Henriksen Lifting Ring • Integrated Henriksen System (IHS)



The HOOKS on this page are all tested and delivered with European Community "MED" CERTIFICATES approved by Det Norske Veritas. They are also approved by Transport Canada (several other certificates are also available on request). Test certificates are based upon IMO / SOLAS.



H. Henriksen AS
 Træleborgveien 15
 3112 Tjønsberg
 Phone: 333 78 400
 Mail: hooks@hhenriksen.com

For more information please visit: www.hhenriksen.com

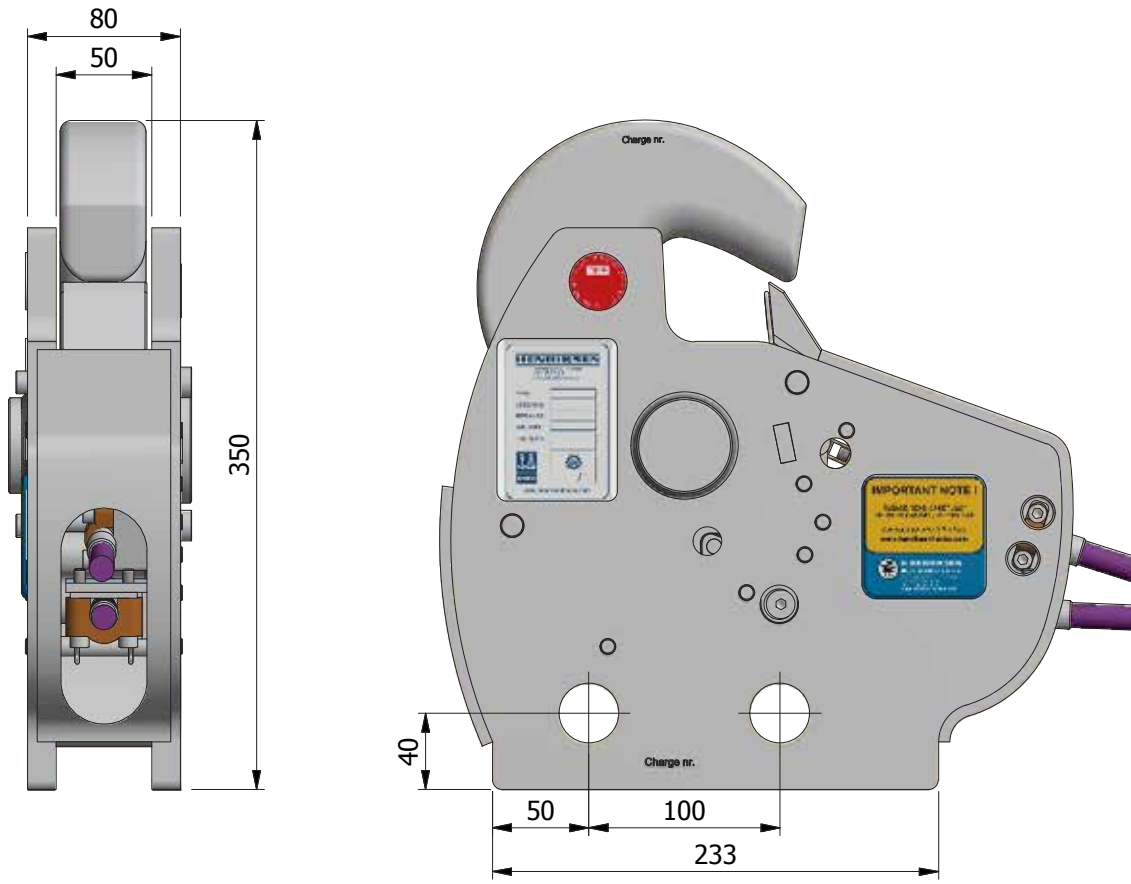

PART NO.	HOOK	WLL	A	B	C	D	E	F	G	H	WEIGHT
HH001963	HMKRHI 12	12 000 kg	-	-	-	-	-	-	-	-	29,5 kg

Materials	High quality stainless steel
Warranty	5 years (When the re-certification and annual inspection is followed)
Documentation	Certificates, Installation-, Operation-, and Maintenance Manual
Packaging	Wooden case
Optional Accessories	<ul style="list-style-type: none"> • Certified bolts and nuts • Henriksen Swivel Joint • Henriksen Lifting Ring • Integrated Henriksen System (IHS)



The HOOKS on this page are all tested and delivered with European Community "MED" CERTIFICATES approved by Det Norske Veritas. They are also approved by Transport Canada (several other certificates are also available on request). Test certificates are based upon IMO / SOLAS.

For more information please visit: www.hhenriksen.com



H. Henriksen AS
 Træleborgveien 15
 3112 Tjønsberg
 Phone: 333 78 400
 Mail: hooks@hhenriksen.com

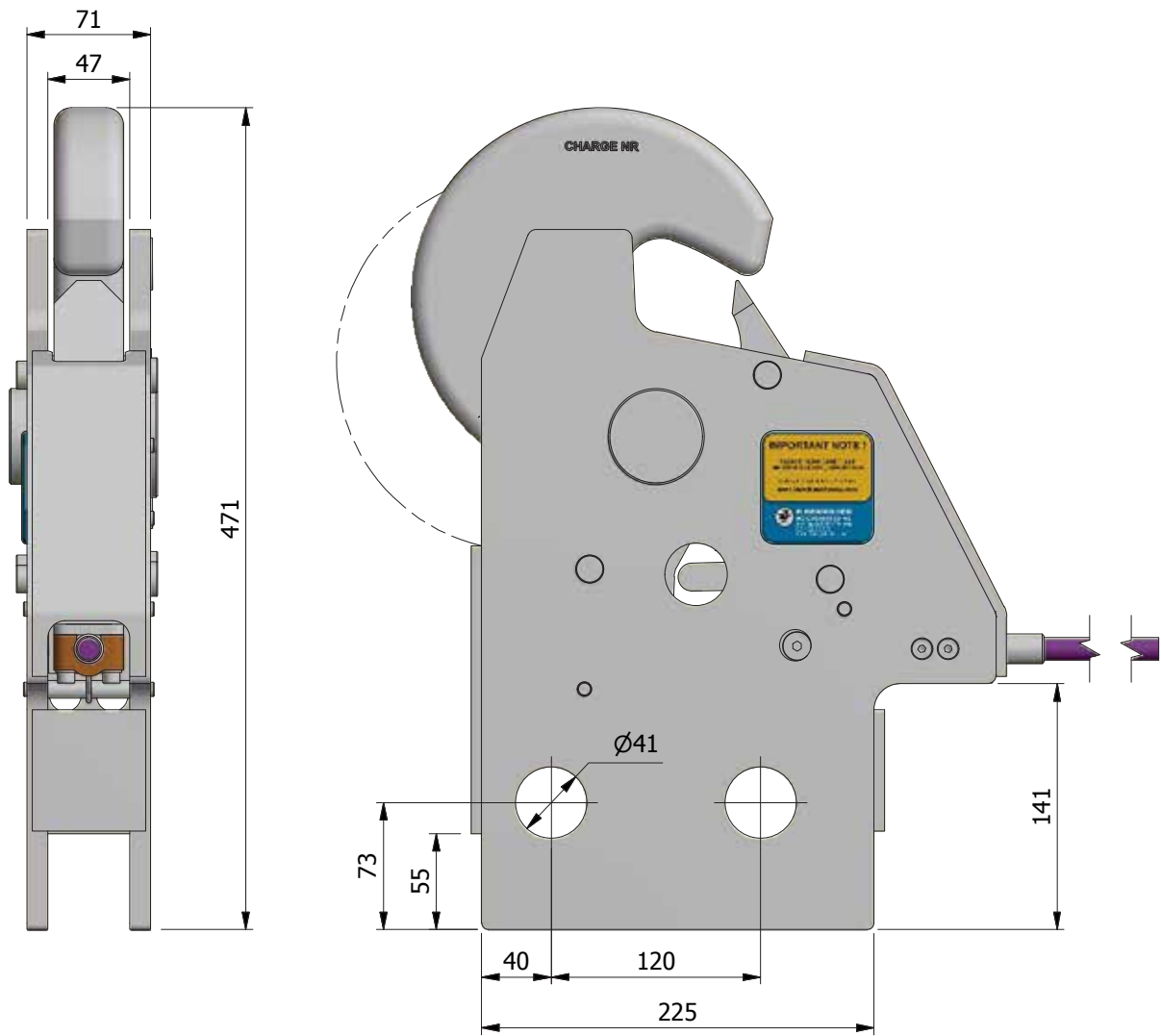

PART NO.	HOOK	SWL	A	B	C	D	E	F	G	H	WEIGHT
HH002637	HMKRHF 15	15 000 kg	-	-	-	-	-	-	-	-	21,5 kg

Materials	High quality stainless steel
Warranty	5 years (When the re-certification and annual inspection is followed)
Documentation	Certificates, Installation-, Operation-, and Maintenance Manual
Packaging	Wooden case
Optional Accessories	<ul style="list-style-type: none"> • Certified bolts and nuts • Henriksen Swivel Joint • Henriksen Lifting Ring • Integrated Henriksen System (IHS)



The HOOKS on this page are all tested and delivered with European Community "MED" CERTIFICATES approved by Det Norske Veritas. They are also approved by Transport Canada (several other certificates are also available on request). Test certificates are based upon IMO / SOLAS.



H. Henriksen AS
 Træleborgveien 15
 3112 Tjønsberg
 Phone: 333 78 400
 Mail: hooks@hhenriksen.com

For more information please visit: www.hhenriksen.com

NORSOK COMPLIANT HOOKS

HOOKS
SAFETY QUICK RELEASE HOOKS



NORHMK 5 / 10 / 15 HMKWS 8 / 15 / 22,5

The NORHMK Hook type incorporates a new kind of swivel that pivots both sideways, forwards and backwards and is able to take up the side loads required by Norsok R-002:2017 with a safety factor of 9.

HOOK	NORHMK
RING	HLR
SWIVEL JOINT	INTEGRATED

NORSOK COMPLIANT

The NORHMK Hooks are specially designed with an integrated swivel joints and is approved by DNV to be compliant with the NORSOK R-002:2017 Lifting Equipment regulations. The NORHMK Hooks are based on our HMKG range and has the same safe handle and large lifting ring skid zone design - resulting in a easier and safer lifting operation.



NORSOK STANDARD / SOLAS STANDARD

This NORSOK standard is developed with broad petroleum industry participation by interested parties in the Norwegian petroleum industry and is owned by the Norwegian petroleum industry represented by The Norwegian Oil Industry Association (OLF) and The Federation of Norwegian Industry. The NORSOK standard is a requirement mainly within Norway and for Norwegian based vessels and equipment, but may also be used elsewhere.

Our NORSOK compliant hooks can also be applied as SOLAS compliant hooks only, with a safety factor of 6 and a rating of 8 000 kg, 15 000 kg and 22 500 kg respectively. In case the hook is certified both as NORSOK and SOLAS compliant hook, the NORSOK SWL shall apply. Please contact us for more details.

NORSOK LIFTING EQUIPMENT REQUIREMENTS

The dynamic forces caused by a MOB boat floating in the sea relative to a stationary platform makes it necessary with a safety factor as high as 9. Also the Hooks have to withstand full SWL in angles +/-15° in both side-side and front-back directions.



LIFTING RINGS

We supply Henriksen original lifting rings for all Henriksen hooks. They are safe and easy to operate with handles that provide a good grip. We strongly recommend the use of our Henriksen lifting rings with our Henriksen hooks as these have geometry that is designed to fit together.

OPERATION OF AN OFF-LOAD HOOK

Launch

1. When the boat is being lowered down and is close to water level, remove the safety pin and release the hook handle.
2. When the boat is waterborne, the hook automatically releases the lifting ring.

Recovery

1. Prepare the hook for recovery by lifting the handle and inserting the safety pin.
2. Grab the lifting ring and connect it by pushing it into the hook.

INTEGRATED HENRIKSEN SYSTEM

All Henriksen HMK hooks can be used in combination with an Integrated Henriksen System (IHS) and a painter hook. We recommend using a IHS system anywhere applicable as it removes the possibility of certain major operator errors and thereby significantly reduces operational risk.

- All materials used in the Henriksen Hooks are high quality and suitable for marine environment (saltwater proof). The hooks are made of stainless steel and duplex steel.
- All hooks are delivered in a practical wooden box.

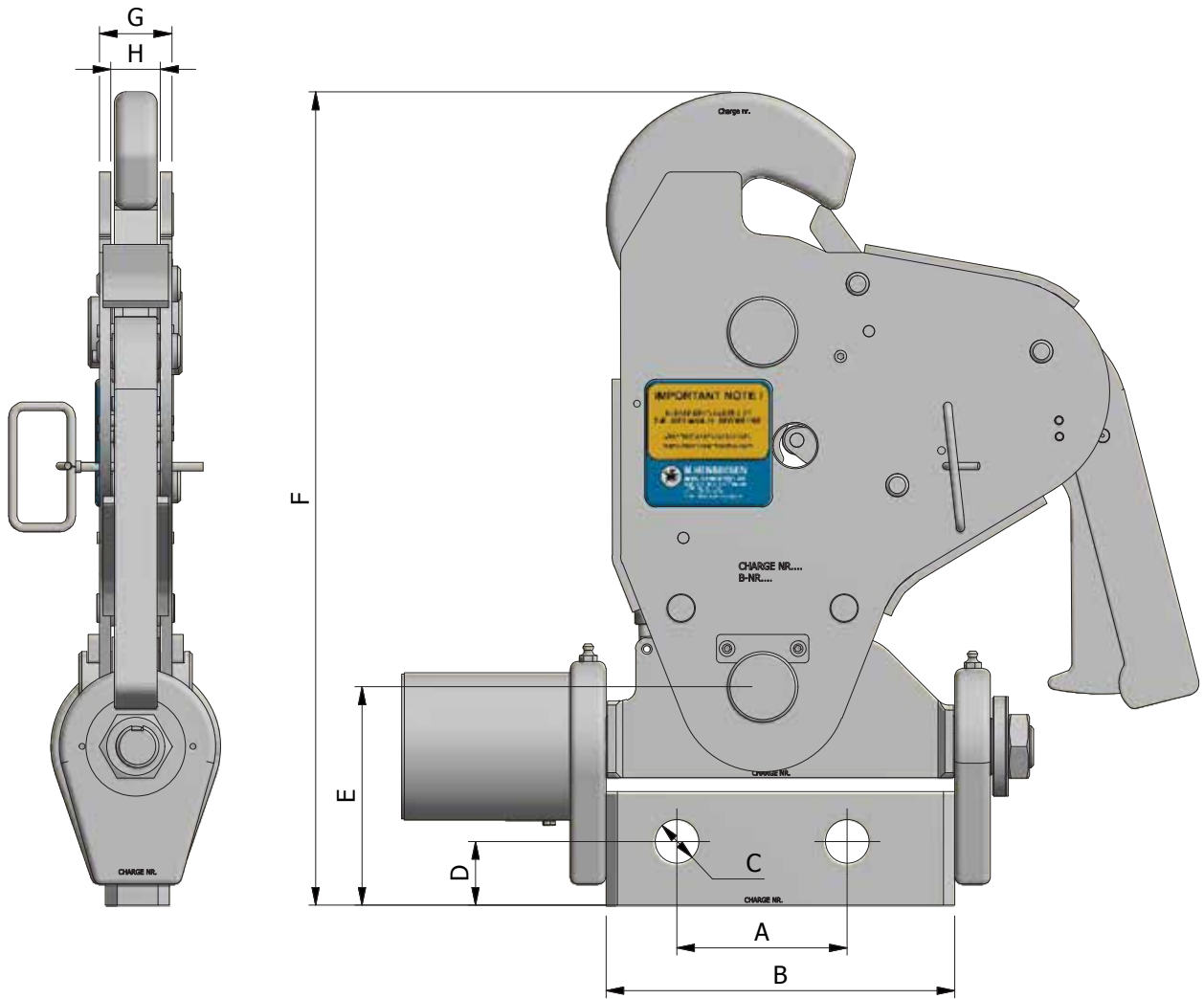

PART NO.	HOOK	SWL	A	B	C	D	E	F	G	H	WEIGHT
HH005972	NORHMKG 5	5 000 kg	120	246	24,5	49	154	574	51	35	47,5 kg
HH000234	NORHMKR 5	5 000 kg	120	246	24,5	49	154	574	51	35	48,1 kg
HH007544	NORHMKG 10	10 000 kg	-	340	-	-	180	528	75	51	65,7 kg
HH007676	NORHMKR 10	10 000 kg	-	340	-	-	180	528	75	51	64,5 kg
HH007542	NORHMKG 15	15 000 kg	-	340	-	-	180	535	86	56	67,1 kg
HH007543	NORHMKR 15	15 000 kg	-	340	-	-	180	535	86	56	64,9 kg

Materials	High quality stainless steel
Warranty	5 years (When the re-certification and annual inspection is followed)
Documentation	Certificates, Installation-, Operation-, and Maintenance Manual
Packaging	Wooden case
Optional Accessories	<ul style="list-style-type: none"> • Certified bolts and nuts • Henriksen Lifting Ring • Integrated Henriksen System (IHS)



The HOOKS on this page are all tested and delivered with product certificate and approved by Det Norske Veritas (DNV).

For more information please visit: www.hhenriksen.com

HENRIKSEN

H. Henriksen AS
 Træleborgveien 15
 3112 Tjønsberg
 Phone: 333 78 400
 Mail: hooks@hhenriksen.com

TWIN HOOKS SYSTEMS

HOOKS
SAFETY QUICK RELEASE HOOKS

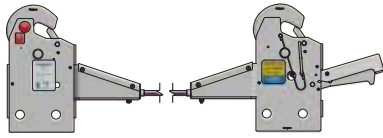

TWIN HOOK SYSTEMS

Henriksen Twin hook system has proven to be the best system for launch and recovery of large workboats for navies and the offshore industry. The system is based on the same principles as our traditional Henriksen single point lift.

HOOK	HMKTW*
RING	HLR
SWIVEL JOINT	HSL

TWIN HOOK

We deliver twin systems for different types of crafts in several versions. The system can be operated manually, pneumatic or electrically. We can also integrate the painter hook in to the system. This will reduce the risk of operational danger when launch and recover the boat.

The hooks are off-load hooks (inherently safe system) and a twin system is the safest way to launch a tender, interceptor or workboat which does not require approval as a lifeboat/FRC.



LIFTING RINGS

We supply Henriksen original lifting rings for all Henriksen hooks. They are safe and easy to operate with handles that provide a good grip. We strongly recommend the use of our Henriksen lifting rings with our Henriksen hooks as these have geometry that is designed to fit together.

OPERATION OF AN OFF-LOAD HOOK

Launch

1. When the boat is being lowered down and is close to water level, activate the twin release system.
2. When the boat is waterborne, the hooks automatically release the lifting rings.

Recovery

1. Prepare the hooks for recovery by resetting the system.
2. Grab the lifting rings and connect them by pushing them into the hooks.

INTEGRATED HENRIKSEN SYSTEM

All Henriksen HMK hooks can be used in combination with an Integrated Henriksen System (IHS) and a painter hook. We recommend using a IHS system anywhere applicable as it removes the possibility of certain major operator errors and thereby significantly reduces operational risk.

- All materials used in the Henriksen Hooks are high quality and suitable for marine environment (saltwater proof). The hooks are made of stainless steel and duplex steel.
- All hooks are delivered in a practical wooden box.



TWIN HOOK SYSTEM SAFETY

SYNCHRONIZED

When lifting a vessel with a twin hook setup, it is important that the hooks are synchronized so that both hooks open and close at the same time. All our twin hook systems are designed this way.

ONE HOOK IS OFF-LOADED: BOTH HOOKS STAY CLOSED

All of our twin hook systems are designed with a connection between the two hooks that ensures that both hooks will stay closed if only one of the two are off-loaded.

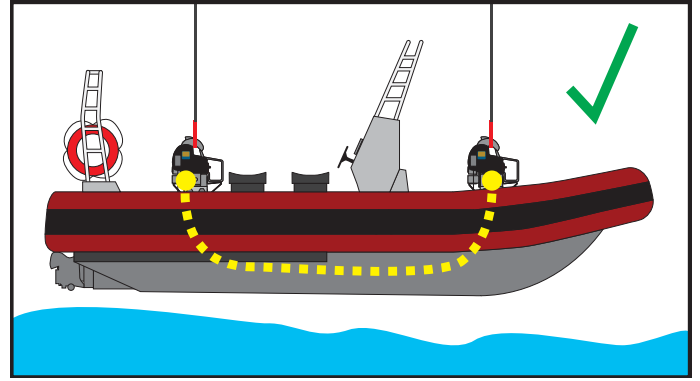
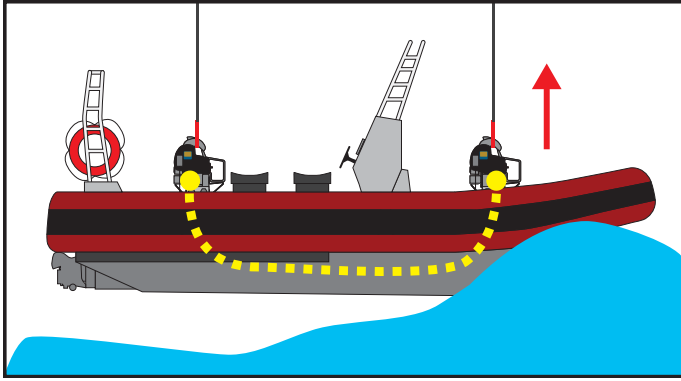

BOTH HOOKS ARE OFF-LOADED: BOTH HOOKS OPEN

All of our twin hook systems are designed with a connection between the two hooks that ensures that both hooks will open at the same time.

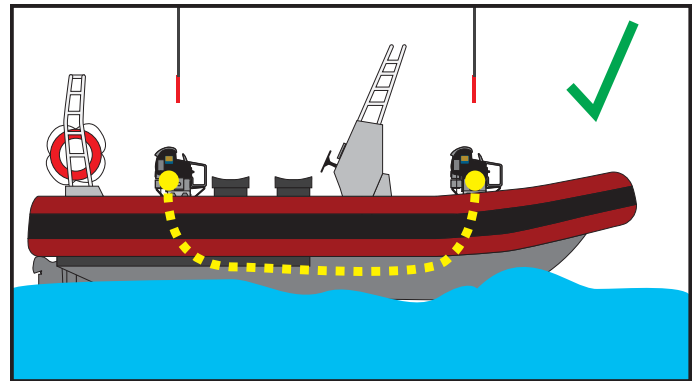
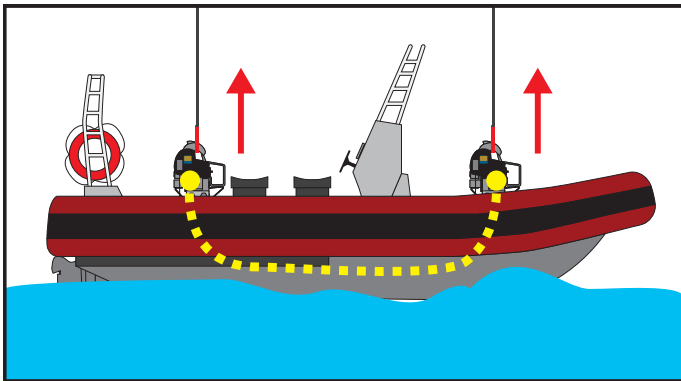

TWIN SYSTEM WITH IHS

All twin systems can be delivered with a painter in a IHS configuration for a even safer operation.

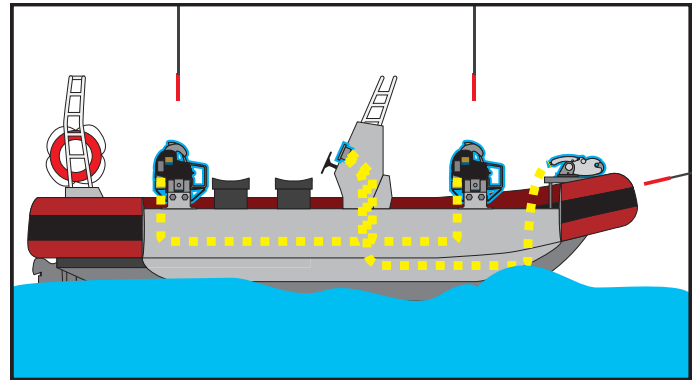
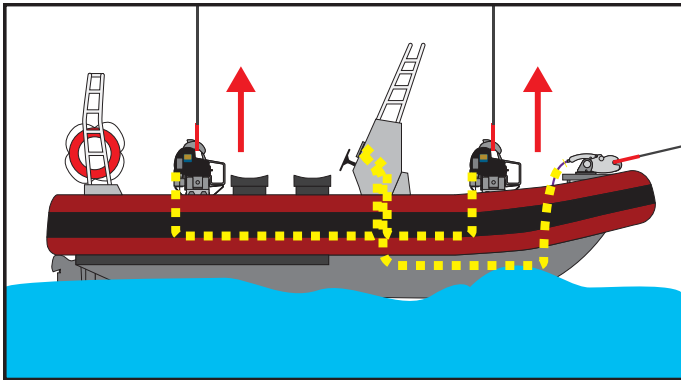

The HOOKS on this page are all tested and delivered with product certificates.

For more information please visit: www.hhenriksen.com

HENRIKSEN

H. Henriksen AS
 Træleborgveien 15
 3112 Tjønsberg
 Phone: 333 78 400
 Mail: hooks@hhenriksen.com

HMKTW* / HHSRT TWIN HOOK SYSTEMS

HMKTW
Manual Simultaneous Release Twin System
(7 / 10 / 16 / 30)

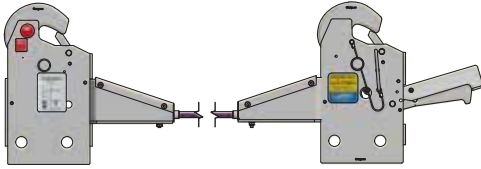

HMKTWE
Electric Simultaneous Release Twin System
(10 / 16 / 24)



HMKTWV
Remote Simultaneous Release Twin System
with vertical cable entry
(7 / 10 / 16 / 30)

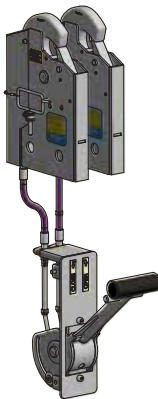

HHSRT
Electric Simultaneous Release Twin System
(24)

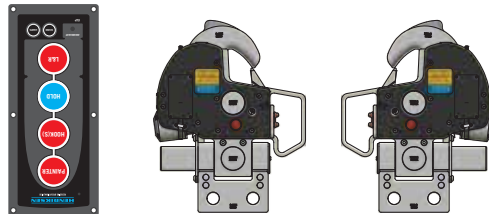

Materials	High quality stainless steel
Warranty	5 years (When the re-certification and annual inspection is followed)
Documentation	Certificates, Installation-, Operation-, and Maintenance Manual
Packaging	Wooden case
Optional Accessories	<ul style="list-style-type: none"> • Certified bolts and nuts • Henriksen Swivel Joint • Henriksen Lifting Ring • Integrated Henriksen System (IHS)

The HOOKS on this page are all tested and delivered with product certificates.

For more information please visit: www.hhenriksen.com

HENRIKSEN

H. Henriksen AS
Træleborgveien 15
3112 Tjønsberg
Phone: 333 78 400
Mail: hooks@hhenriksen.com

CRANE HOOKS

HOOKS
SAFETY QUICK RELEASE HOOKS



HCH 1,5
HCHT 3,5 / 6,5 / 10

Off-load Lifting hook for fast rescue crafts and other types of boats with lifting slings.

HOOK HCH

CRANE HOOKS

The HCH hooks are off-load crane hooks designed for lifting Fast Rescue Crafts, Man-Over-Board boats, Rigid Inflatable Boats (RIB) and tenders with a total weight of up to 10 000 kg. The HCH hooks are designed for use on small boats for military, offshore and the leisure market.

LIGHT WEIGHT

The Henriksen Crane Hooks differs from all our other hooks by being attached to the crane/davit instead of the boat. The advantage of attaching the hook to the boat, is that the weight of the crane line is kept at a minimum. A light line is safer and easier to handle, especially in rough weather. A crane hook adds more weight to the crane/davit line than a lifting ring and it is therefore critical to keep the weight of the crane hook at a minimum. All our crane hooks have therefore been designed to be as light as possible, and every HCH hook (except the smallest HCH 1,5) are all made exclusively out of grade 5 Titanium.



OPERATION OF AN OFF-LOAD CRANE HOOK

Launch

1. When the boat is close to water level, pull the release cord.
2. When the boat is waterborne, the hook will release automatically.

Recovery

1. Grab the hook.
2. Prepare for recovery by setting the reset lever into "closed position".
3. Close the hook.
4. Connect the lifting ring by pushing it into the hook.

The HCH hooks are available with several different connectors, depending on hook model. Please contact us for details about the different hooks and their connector options.

Thimble

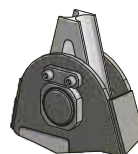

Shackle

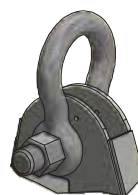

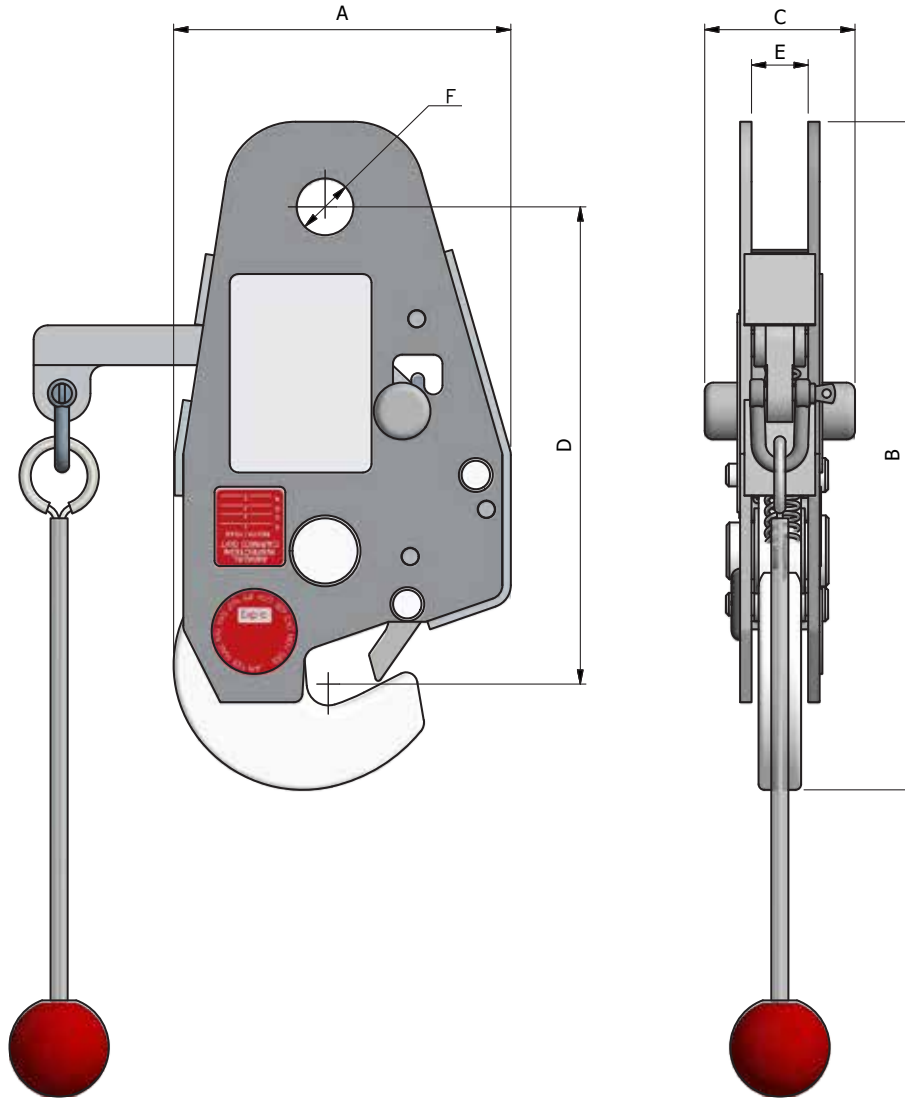

PART NO.	HOOK	SWL	A	B	C	D	E	F	WEIGHT
HH000032	HCH 1,5	1 650 kg	118	235	53	168	20	20	2,22 kg

Materials	High quality stainless steel / grade 5 titanium
Warranty	5 years (When the re-certification and annual inspection is followed) for all HCHT Hooks
Documentation	Certificates, Installation-, Operation-, and Maintenance Manual
Packaging	Wooden case
Optional Accessories	<ul style="list-style-type: none"> • Certified Thimbles and Shackles • Henriksen Lifting Ring



The HOOKS on this page are all tested and delivered with European Community "MED" CERTIFICATES approved by Det Norske Veritas. They are also approved by Transport Canada (several other certificates are also available on request). Test certificates are based upon IMO / SOLAS.

For more information please visit: www.hhenriksen.com



H. Henriksen AS
 Træleborgveien 15
 3112 Tjønsberg
 Phone: 333 78 400
 Mail: hooks@hhenriksen.com

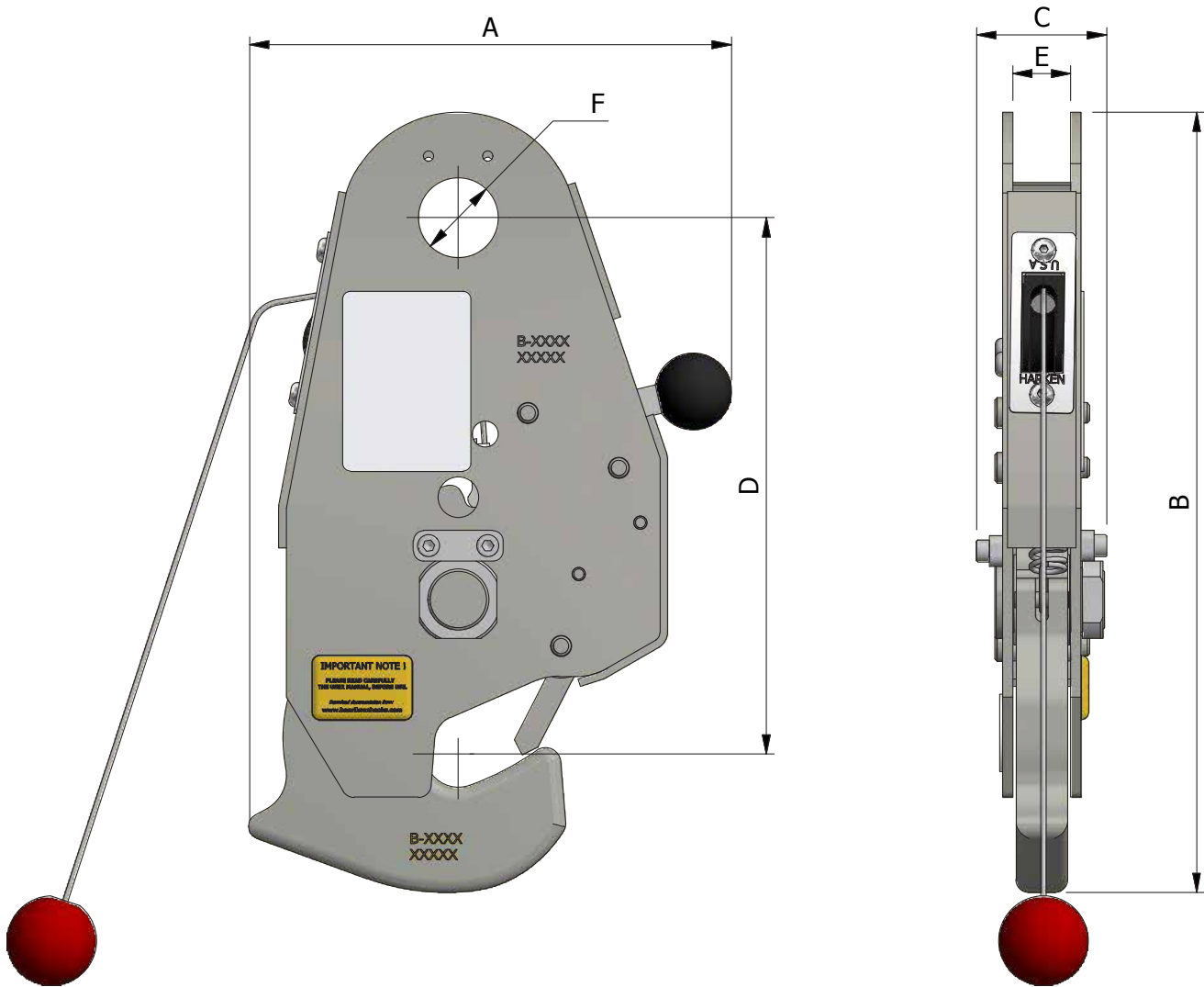

PART NO.	HOOK	SWL	A	B	C	D	E	F	WEIGHT
HH006911	HCHT 3,5	3 500 kg	177	303	50	209	31	31	2,70 kg
HH000094	HCHT 6,5	6 500 kg	198	353	62	253	44	30	5,90 kg
HH003470	HCHT 10	10 000 kg	231	379	78	251	57	40	7,70 kg

Materials	High quality stainless steel / grade 5 titanium
Warranty	5 years (When the re-certification and annual inspection is followed) for all HCHT Hooks
Documentation	Certificates, Installation-, Operation-, and Maintenance Manual
Packaging	Wooden case
Optional Accessories	<ul style="list-style-type: none"> • Certified Thimbles and Shackles • Henriksen Lifting Ring



The HOOKS on this page are all tested and delivered with European Community "MED" CERTIFICATES approved by Det Norske Veritas. They are also approved by Transport Canada (several other certificates are also available on request). Test certificates are based upon IMO / SOLAS.

For more information please visit: www.hhenriksen.com



H. Henriksen AS
 Træleborgveien 15
 3112 Tjønsberg
 Phone: 333 78 400
 Mail: hooks@hhenriksen.com

LIFERAFT HOOKS

HOOKS
SAFETY QUICK RELEASE HOOKS



HLH 1,5 / 3,5

Off-load / on-load crane hooks for lifting Fast Rescue Crafts, Man-Over-Board boats, Rigid Inflatable Boats, tenders and liferafts.

HOOK HLH

LIFERAFT HOOKS

The HLH hooks are off-load / on-load crane hooks designed for lifting Liferafts and Man-Over-Board boats with a total weight of up to 3500 kg.

The HLH hooks are designed for use for the offshore, military and the cruise ship market. The hooks are available in two versions for 1 500 kg and 3 500 kg loads.

OPERATION OF AN OFF-LOAD LIFERAFT HOOK

To activate the automatic release facility, a liferaft occupant pulls a red knob downwards when the liferaft is just one or two meters above the water.

When the liferaft is waterborne and the load on the hook is less than 30 kg, it opens automatically enabling the liferaft to drift free and for the fall wire to be hoisted in.



If conditions are such that it is not possible to use the automatic release capability, the Henriksen Liferaft Hook also offers a manual opening facility. It can be used if the raft is on the water but is being pulled by a strong current or by vessel movement and the automatic release capacity is not enough. Under these circumstances, a green grip on the hook can be pulled strongly and the hook will open.

When the crane operating crew has recovered the hook, it can be reset quickly and simply for re-use by setting the release handle back to its original position. With the hook element reset it can be clipped into the lifting arrangement on the next liferaft for launching.



LIFTING RINGS

We supply Henriksen original lifting rings for all Henriksen hooks. They are safe and easy to operate with handles that provide a good grip. We strongly recommend the use of our Henriksen lifting rings with our Henriksen hooks as these have geometry that is designed to fit together.

Mount the hook at the end of the wire from the crane or davit, or use a shackle. Henriksen top attachments (shackle) are available.

The hook is manufactured according to latest regulation and tested to the LSA code.

- All materials used in the Henriksen Hooks are high quality and suitable for marine environment (saltwater proof).
- All hooks are delivered in a practical wooden box.

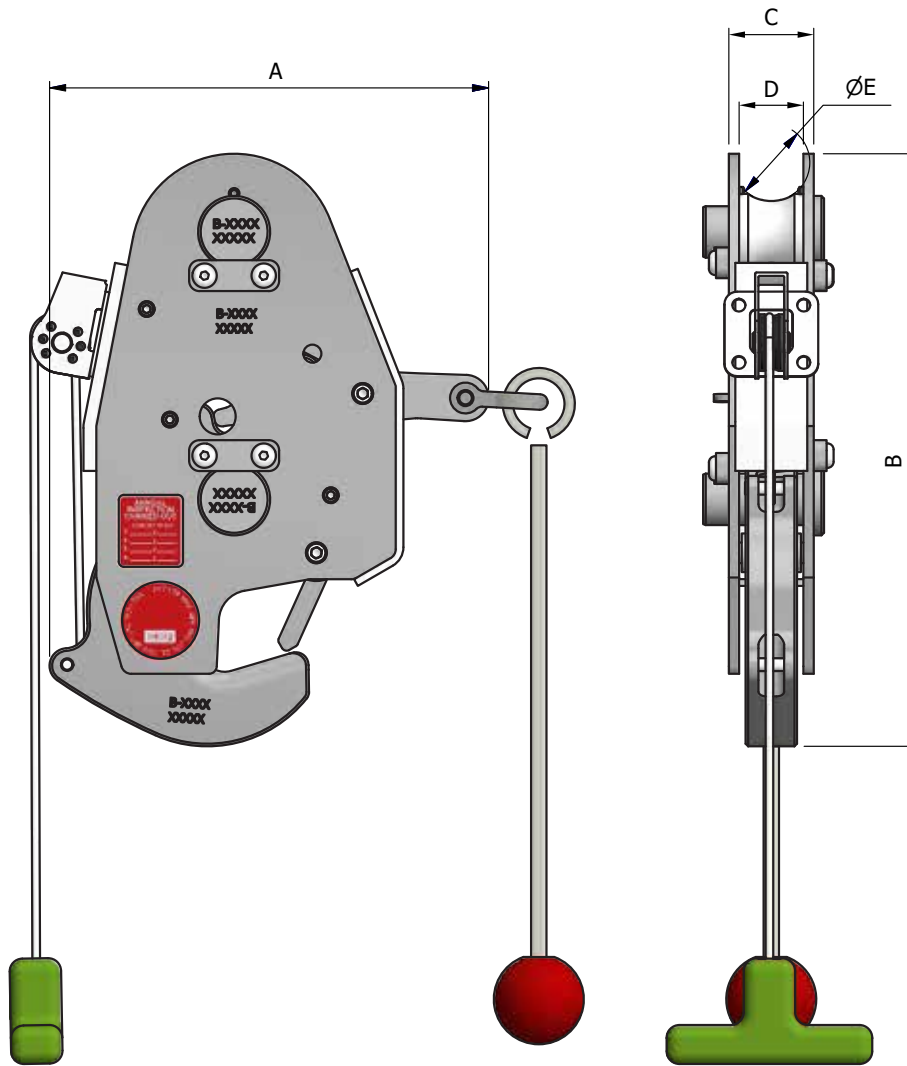

PART NO.	HOOK	SWL	A	B	C	D	E	WEIGHT
HH000236	HLH 1,5	1 500 kg	136	231	33	25	Ø30	3,3 kg
HH000177	HLH 3,5	3 500 kg	202	288	44	34	Ø38	6,0 kg

Materials	High quality stainless steel
Warranty	5 years (When the re-certification and annual inspection is followed) for all HLH Hooks
Documentation	Certificates, Installation-, Operation-, and Maintenance Manual
Packaging	Wooden case
Optional Accessories	<ul style="list-style-type: none"> • Certified shackles • Henriksen Lifting Ring



The HOOKS on this page are all tested and delivered with European Community "MED" CERTIFICATES approved by Det Norske Veritas. They are also approved by Transport Canada (several other certificates are also available on request). Test certificates are based upon IMO / SOLAS.

For more information please visit: www.hhenriksen.com



H. Henriksen AS
 Træleborgveien 15
 3112 Tjønsberg
 Phone: 333 78 400
 Mail: hooks@hhenriksen.com

PAINTER HOOKS

HOOKS
SAFETY QUICK RELEASE HOOKS



HPH 2,5 / 5

On-load release painter hook for fast rescue crafts, RIBs, MOBs working boats and other types of boats.

HOOK	HPH
RING	HPR

PAINTER HOOKS

A Henriksen Painter Hook is placed in the bow of e.g. a MOB boat and connected to a painter line in order to ensure that the MOB boat is kept in the correct direction and position during both launch and recovery. The Henriksen Painter Hooks are designed for boats with a total weight of up to 20 000 kg. Our guidelines dictate that the painter hook rating (SWL) should be at least half of the total weight of the boat.



OPERATION OF A PAINTER HOOK

1. Before launch: connect the painter line to the painter hook.
2. Connect the main lifting hook.
3. Lower / launch the boat.
4. Activate the hook opening mechanism when the boat is clear of all objects and close to the water.
5. The main lifting hook open opens/releases when the boat hits the water.
6. Release the painter hook when crew is ready.

Most of our painter hooks are operated with a remote control handle. This makes it easy for the operator in the helms mans position to have full control over the boat and thereby reducing operational risk.

The ELA electric actuator is an accessory for the painter hook that is suitable for both standalone use, as well as together with a lifting hook and the ELP control panel. This combination will also provide a safer lifting operation provided by safety features integrated in the control panel.

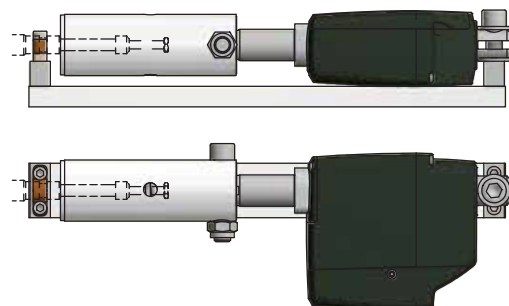
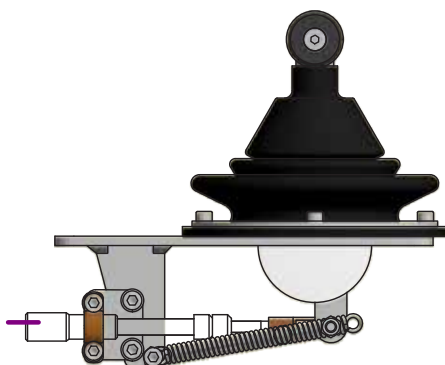

All our painter hooks can be used together with the Integrated Henriksen System (IHS), which eliminates the possibility of opening the painter hook before the main hook.

All Henriksen Hooks are produced with high quality stainless steel and given a polished finish before delivery.

HPH HOOKS

HPH 2,5

HH001543

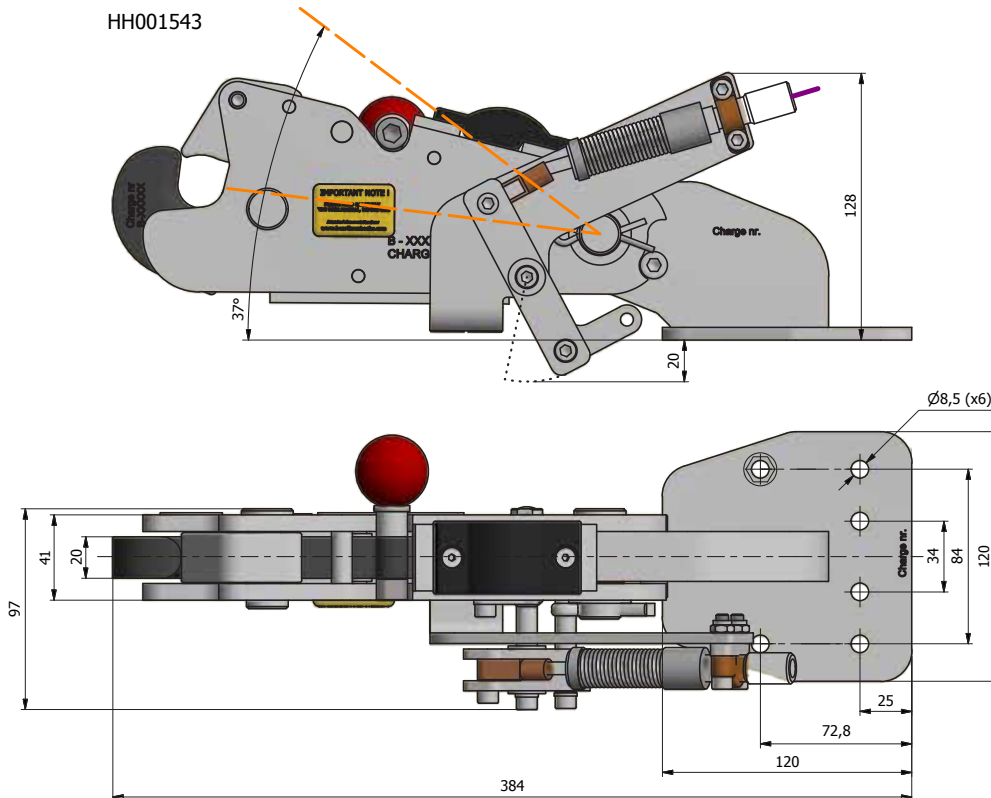

Alternative cable entry versions

HH000103 Angled

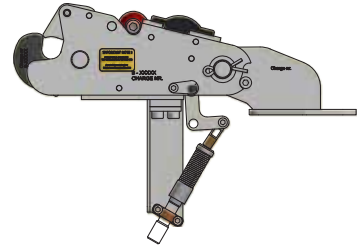

HH001542 Perpendicular

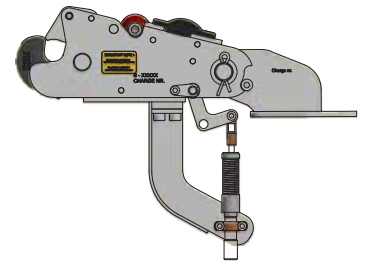

HPH 5

HH001959

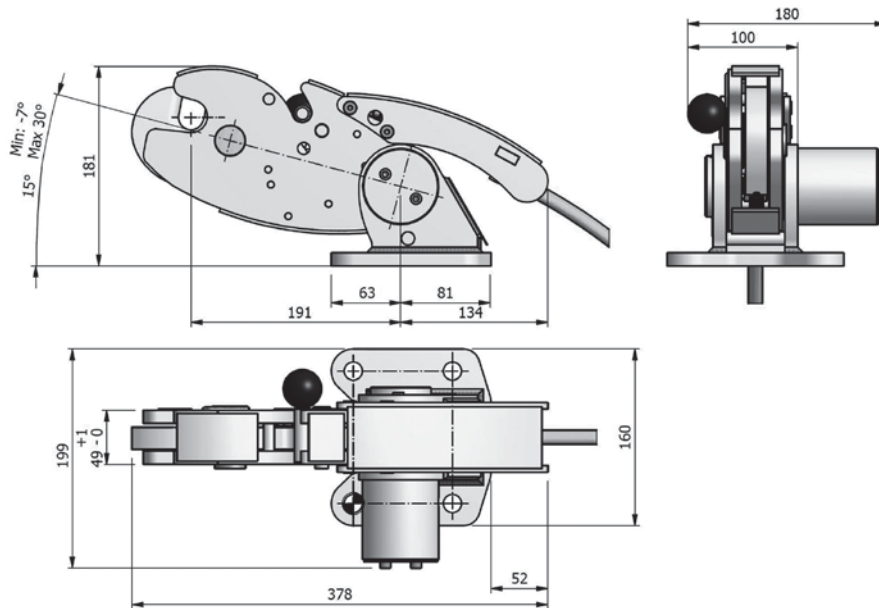

Materials	High quality stainless steel
Warranty	5 years (When the re-certification and annual inspection is followed)
Documentation	Certificates, Installation-, Operation-, and Maintenance Manual
Packaging	Wooden case
Optional Accessories	<ul style="list-style-type: none"> Henriksen Painter Ring Integrated Henriksen System (IHS)



The HOOKS on this page are all tested and delivered with product certificate and Type Approval Certificate from Det Norske Veritas (DNV) according to DNVGL-ST-0378

For more information please visit: www.hhenriksen.com



H. Henriksen AS
 Træleborgveien 15
 3112 Tjønsberg
 Phone: 333 78 400
 Mail: hooks@hhenriksen.com

CAPTURE CLAW PAINTER HOOKS

HOOKS
SAFETY QUICK RELEASE HOOKS

HPHA 2,5 / 5

On-load release painter hook and capture claw for fast rescue crafts, RIBs, MOBs, working boats and other types of boats.

HOOKHPHA

CAPTURE CLAW HOOKS

A Henriksen Capture Claw is placed in the bow of e.g a MOB boat and can be used as both a ramp capture claw hook and a Painter hook for normal davit launch and recovery. This makes the hook very versatile for multi launch operations.

The HPHA are designed for boats with a total weight of up to 10 000 kg. Our guidelines dictates that the painter hook rating (SWL) should be at least half of the total weight of the boat.

Our HPHA hooks are operated with a remote control handle. This makes it easy for the operator in the helms mans position to have full control over the boat and thereby reducing operational risk. Alternatively, the HPHA also have a manual release at the hook.

RAMP OPERATION

The HPHA hooks can, if used together with a catch system, be used as a RAMP hook. The HPHA can catch and secure itself to a horizontally suspended catch rope. A typical Launch and recovery operation from a ramp would be as follows:

Launch

1. Crew and boat is made ready to release while the boat is in the ramp.
2. The HPHA is released with the remote release handle.
3. The boat slides down the ramp and out into sea.

Recovery

1. The boat align itself with the ramp on the mother vessel.
2. The boat drives up the ramp towards a suspended catch line.
3. The HPHA connects and lock on to the catch line, and the boat is securely fastened to the mother vessel.

PAINTER OPERATION

THE HPHA can also work as a normal Painter hook. See chapter for painter hooks for more information. HPHA are designed to catch a suspended rope, but as a painter hook it can be linked with a steel ring or a rope.



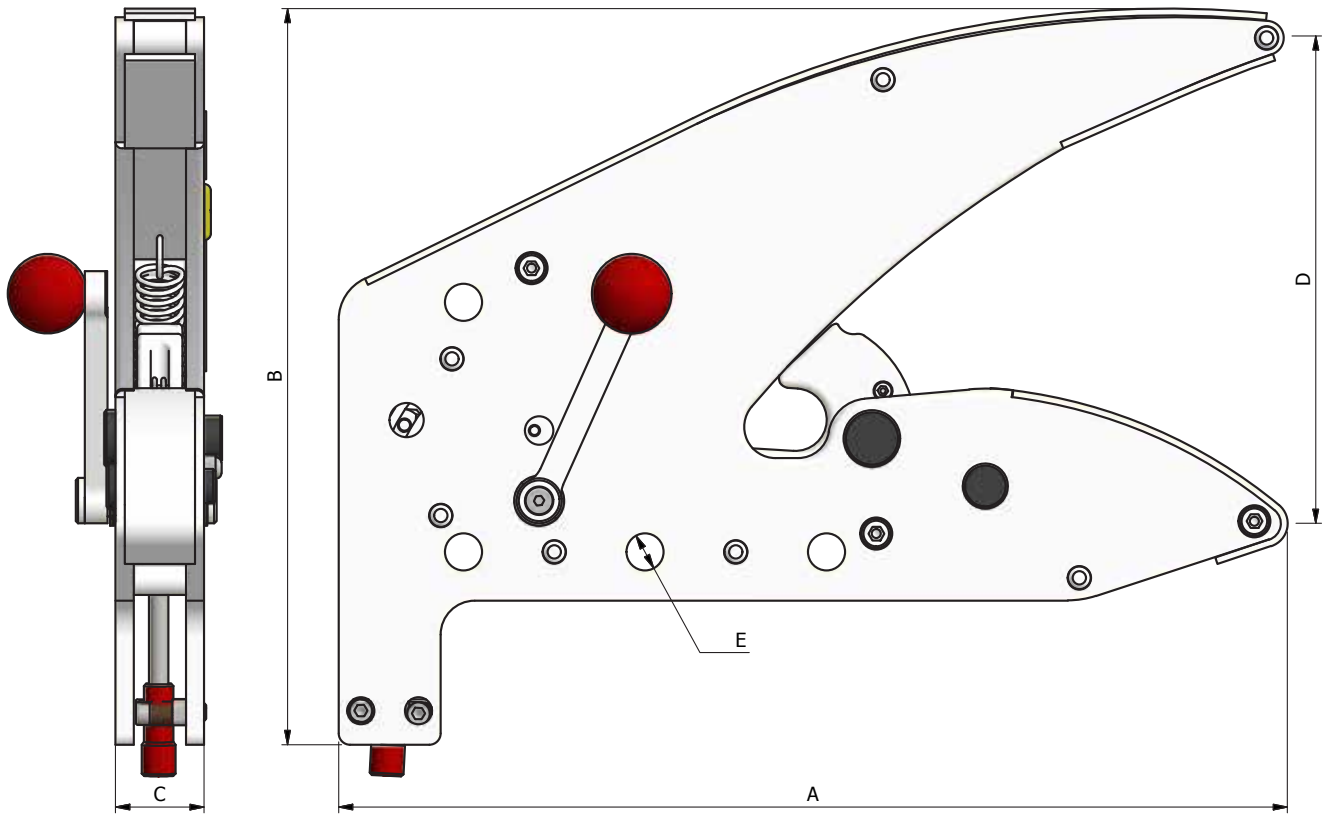

PART NO.	HOOK	WLL	A	B	C	D	E	WEIGHT
HH000164	HPHA 2,5	2 500 kg	418	324	39	215	16,5	11,0 kg
HH003095	HPHA 5,0	5 000 kg	768	528	90	428	20,5	29,6 kg

Materials	High quality stainless steel
Warranty	5 years (When the re-certification and annual inspection is followed)
Documentation	Certificates, Installation-, Operation-, and Maintenance Manual
Packaging	Wooden case
Optional Accessories	<ul style="list-style-type: none"> Henriksen Painter Ring Integrated Henriksen System (IHS)

TOWING HOOKS

HOOKS
SAFETY QUICK RELEASE HOOKS



HTH 2,5 / 5 / 10

For towing and hauling operations. Suitable for smaller work boats, rescue boats or other vessels for use in any towing operation up to 10 000 kg bollard pull (BP).

HOOK

HTH

TOWING HOOK

The Henriksen Towing Hook (HTH) is a series of certified on-load quick release towing hooks with higher quality standard, made for safe and effective towing operations. The hooks are on-load released, and can be released locally or remotely.

SAFETY FEATURES

- Factory overload tested and certified
- Safety factor 6
- Easy to install
- Easy to use
- Use with rope, wire or steel rings
- On-load release up to full SWL in all working angles
- Little to none maintenance needed
- Re-certified by manufacturer every 5 years



ADAPTERS

The HTH hooks can be delivered with different horizontal or vertical adapters for fastening with screws or welding directly into the boat. Please contact us if you have any questions or specific requirements.



HIGH QUALITY

The HTH hooks are made of only high grade stainless steel, which is the same material that is qualified to be used in Life Saving Appliances according to SOLAS. This makes the HTH hooks almost maintenance free. The HTH can be mounted in the marine environment (salt water proof) without the need of any coatings or protection. All Henriksen Hooks are delivered in a practical wooden box.

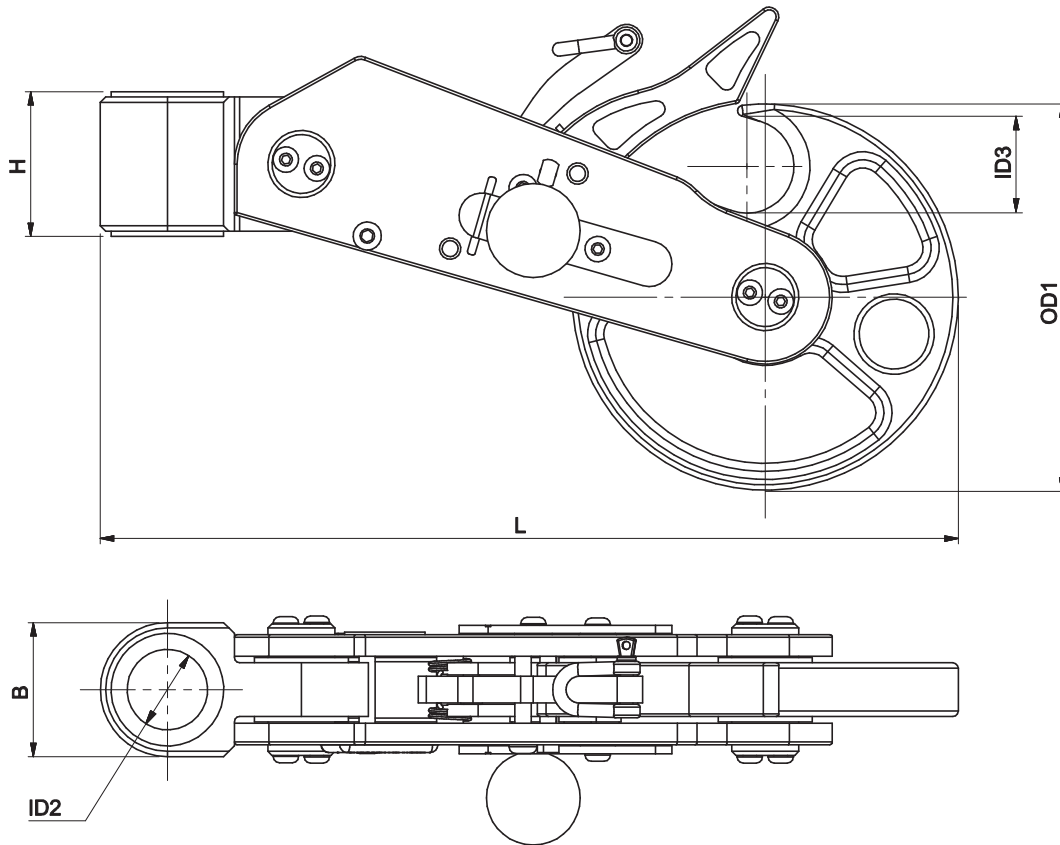

WORKING ANGLES

Vertical: From 0° to 45°
 Horizontal: Depending on installation

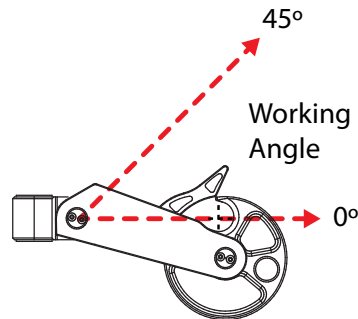

PART NO.	HOOK	SWL	L	H	B	OD1	ID2	ID3	WEIGHT
HH000158	HTH 2,5	2 500 kg	320	54	50	144	30	35	4,70 kg
HH000166	HTH 5,0	5 000 kg	487	94	80	218	40	50	18,0 kg
HH000221	HTH 10,0	10 000 kg	626	114	100	299	50	70	38,1 kg

Materials	High quality stainless steel
Warranty	5 years (When the re-certification and annual inspection is followed)
Documentation	Certificates, Installation-, Operation-, and Maintenance Manual
Packaging	Wooden case
Optional Accessories	<ul style="list-style-type: none"> Certified Adapters



The HOOKS on this page are all tested and delivered with product certificate and Type Approval Certificate from Det Norske Veritas (DNV) according to DNVGL-ST-0378

For more information please visit: www.hhenriksen.com



H. Henriksen AS
 Træleborgveien 15
 3112 Tjønsberg
 Phone: 333 78 400
 Mail: hooks@hhenriksen.com

INTEGRATED HENRIKSEN SYSTEM (IHS)

HOOKS
SAFETY QUICK RELEASE HOOKS

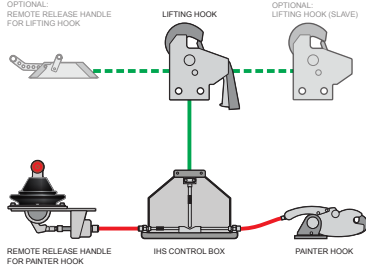

INTEGRATED HENRIKSEN SYSTEM (IHS)

The Integrated Henriksen System is designed to enhance the safety during the launch of a rescue / work boat.

HOOK	ALL
RING	HLR
SWIVEL JOINT	N/A

The Integrated Henriksen System (IHS) is a safety system that increases the safety of lifting operations where a painter hook is used in combination with a lifting hook, and especially when the mothership is moving. One of the most dangerous things that can happen when lifting in speed is releasing the painter hook before the lifting hook which will cause the daughtercraft to be towed by its lifting hook. Using a IHS System ensures that the lifting hook has opened before the painter hook can release the painter line.

The IHS is available both as electric or mechanical system. See the illustrations to the right. The electric system uses flexible electrical wires to connect the components and is controlled with a compact and intuitive control panel. Release of both painter hook and lifting hooks is done with the push of a button. The electric system is easier to use, and takes less room in the boat cockpit panel, but this is not the only advantage. The electric wires are much easier to route and install in the boat. The electrical wires will also not move around when used.

The mechanical version is connected via stainless steel pull/push cables and a painter hook release handle. The lifting hook itself can be opened with a handle on the hook, or be remote released via an optional hook release handle.

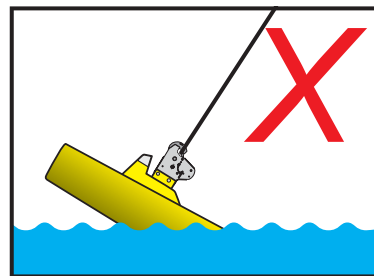
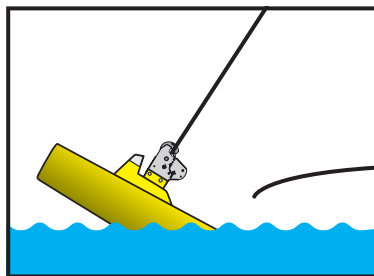
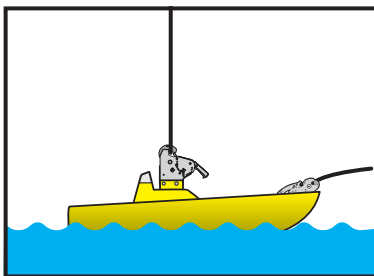

Without IHS:
a dangerous procedural error is possible: Release of painter hook before lifting hook

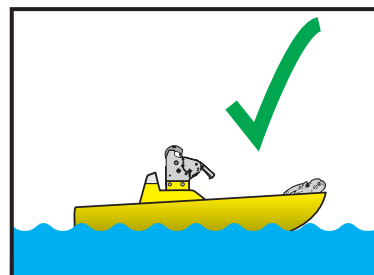
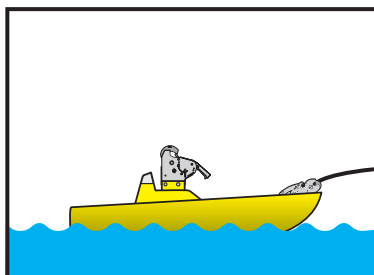
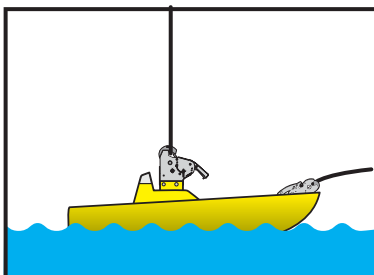

With IHS:
This possibility is removed and lifting hook has to be opened before the painter hook.

Electric

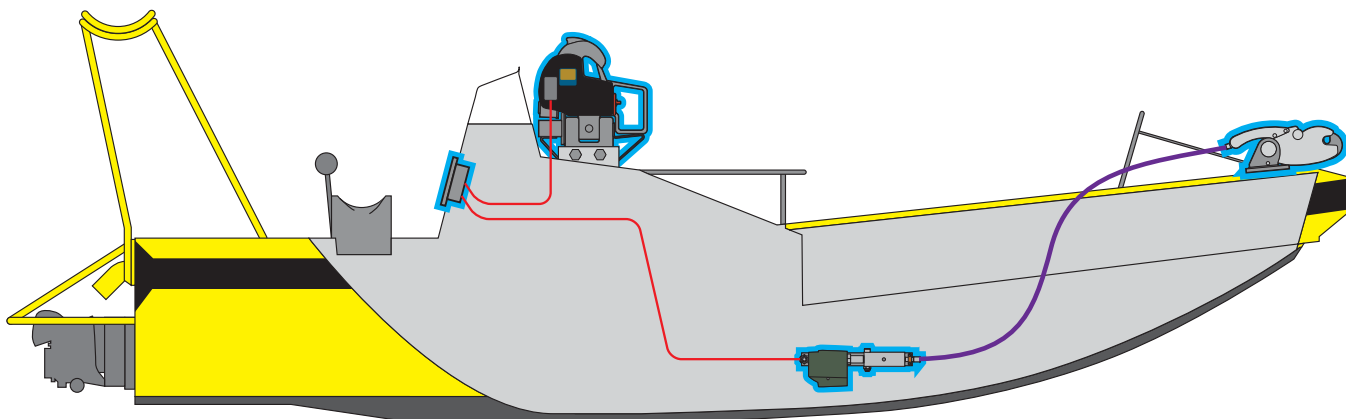

Electric Twin

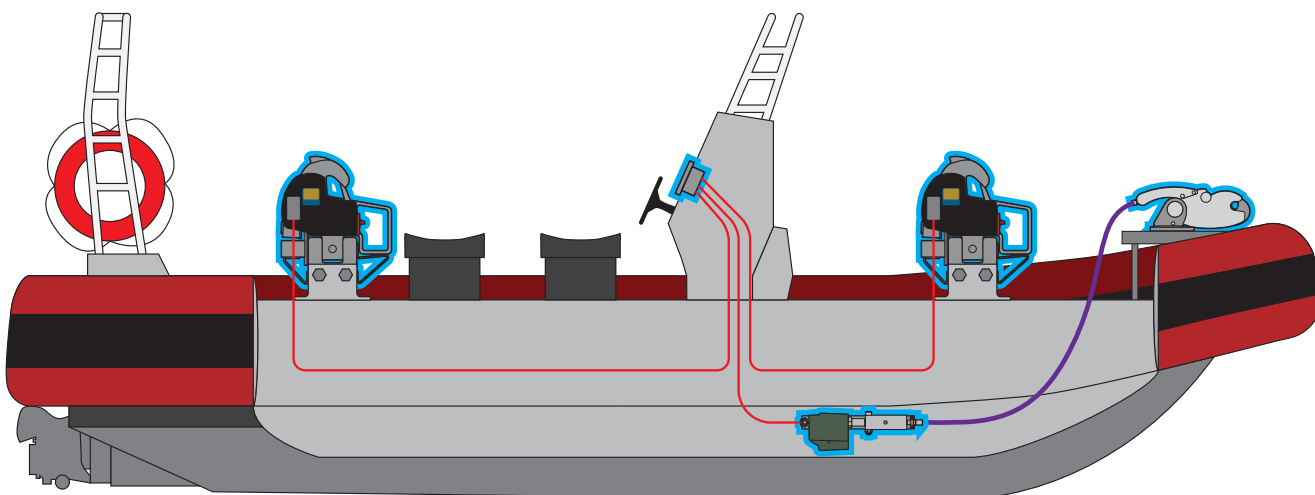

Mechanical

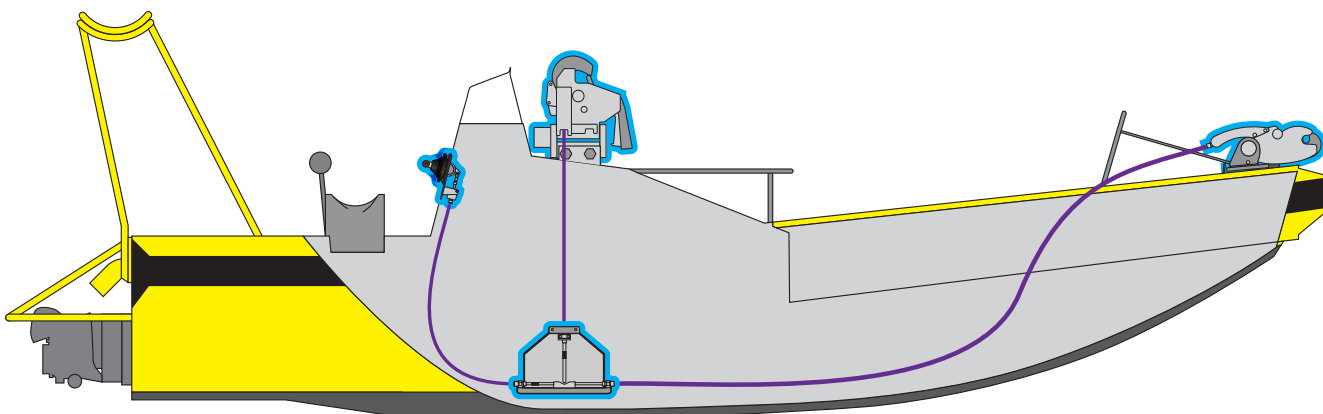

The HOOKS on this page are all tested and delivered with European Community "MED" CERTIFICATES approved by Det Norske Veritas. They are also approved by Transport Canada (several other certificates are also available on request). Test certificates are based upon IMO / SOLAS.

For more information please visit: www.hhenriksen.com

HENRIKSEN

H. Henriksen AS
 Træleborgveien 15
 3112 Tjønsberg
 Phone: 333 78 400
 Mail: hooks@hhenriksen.com

LIFTVIEW

HOOKS
SAFETY QUICK RELEASE HOOKS



LIFTVIEW

The Henriksen Liftview system enables the user to view in real time information about a lift, including load, tilt and roll. The user output is viewed on a screen. The LiftView system contains information about the current hook in use, all performed lifts and so on.

LIFTVIEW

Henriksen Hooks' new sensor system enables us to add sensing, visualization and logging capabilities to any hook in our range. This system will give the user some unique possibilities that will increase operational awareness, and thereby a safer lifting operation.

Key features

- Display accurate hook load in real time
- Log peak loads for every lifting operation
- Log total numbers of lifting operations
- View active and logged lifts as detailed plots with trendlines
- Measure roll and pitch
- Sense hook status (closed, active or open)
- Signal hook status with a external lantern

The sensor information can be used to alarm the user of overload. Optimize boat and crane design based on actual load data as well as creating maintenance routine based on operations.



AWARELIGHT

HOOKS
SAFETY QUICK RELEASE HOOKS

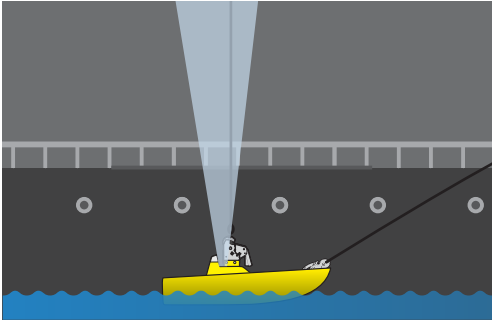

AWARELIGHT

One key element during lifting operations is awareness. The view of the crane/davit operators is often limited and distant, increasing the operational risks. This risk can be minimized by providing the crane/davit operator with more information, and thereby increasing operational awareness. With the Henriksen AwareLight and a compatible hook you provide the crane/davit operator, as well as any other supervising personnel, with quick and easy feedback. The hook state is constantly broadcasted via a strong led-lamp, and a quick look is all you need to identify the current state of the hook.

HENRIKSEN AWARELIGHT

Originally developed as part of the liftview system, the awarelight is now also offered as a standalone feature.

The AwareLight lantern has a narrow field of view which gives good feedback to the crane/davit operator, while not disturbing the boat crew. The AwareLight is useful in both the launch and recovery phase.

In the **launch** phase, continuous light signalizes OK, the hook is closed. The crane/davit operator is told that everything is OK with the hook, and can begin to lift the boat.

When the boat closes in on the water line, the hook operator will activate the hook. The awarelight changes from a continuous light, to a 1 Hz flashing light, telling the crane/davit operator that the boat is ready to be lowered into the water.

As soon as the boat hits the water and the hook opens, the awarelight changes from 1 Hz flashing to 10 Hz (more rapid) flashing, and the crane/davit operator knows that the hook has opened.

In the **recovery** phase, the AwareLight will emit a constant light to signalize to the crane/davit operator that the boat is ready to attach the hook. When the hook is closed, the AwareLight will change the constant light to a 10 Hz flashing light. When the light changes, the crane/davit operator can start lifting the boat.

The AwareLight is placed somewhere near the hook on deck. Optionally you can add a second awarelight in the cockpit, giving the coxswain the same feedback.



LAUNCH

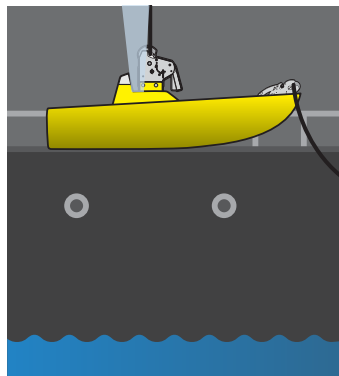

1. Hook closed

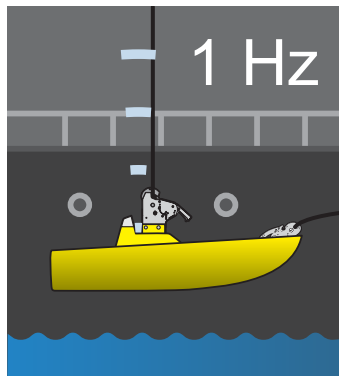

2. Hook activated

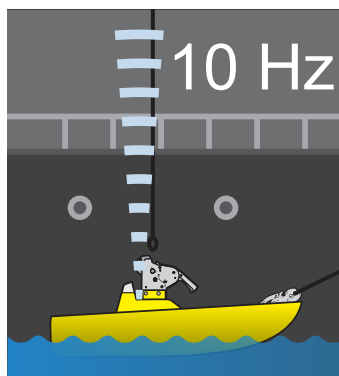

3. Hook open

RECOVERY

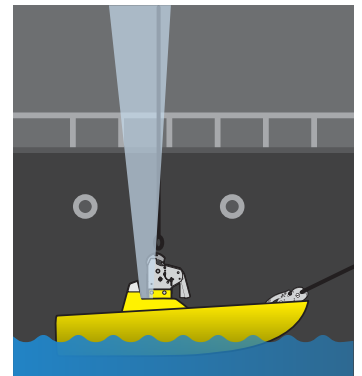

1. Ready to attach hook

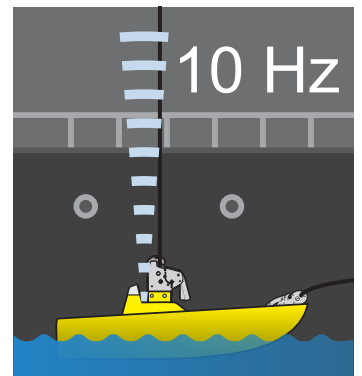

2. Hook closed, ready for lift

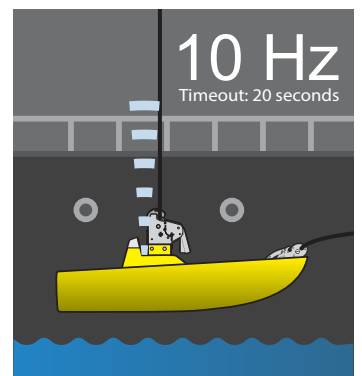

3. Boat is being recovered

BOLT SET

HOOKS
SAFETY QUICK RELEASE HOOKS



BOLT SET

Apply bolts to connect:

- the hook to the swivel joint
- the hook or the swivel joint to the Henriksen adapter
- the hook or the swivel joint to the lifting arrangement of the boat ⁽¹⁾

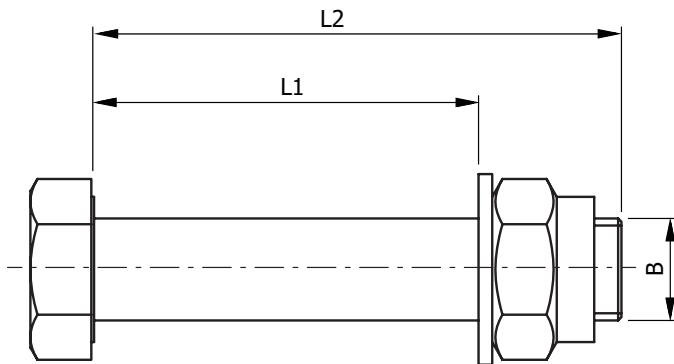

PART NO.	SWL ⁽²⁾	L1 ⁽³⁾	L2	B	Max. torque (Nm)	Between		
						hook and adapter	hook and swivel	swivel and adapter
HH000217	3 500 kg	42	75	M24	70		X	
HH000218	3 500 kg	52	80	M24	70	X		X
HH000219	5 000 kg	53	90	M30	70		X	
HH000212	8 000 kg	73	110	M30	70	X		X
HH000517	12 000 kg	118	150	M30	70	X	X	X
HH000681	15 000 kg	75	163	Ø40 / M36 ⁽⁴⁾	70	X	X	

⁽¹⁾ The length of the bolt is specified by the boat builder, the bolt should be unthreaded in the lifting cross-section.

⁽²⁾ The SWL of the hook, swivel joint or adapter.

⁽³⁾ Unthreaded length.

⁽⁴⁾ Stud bolt: shaft Ø40 with M36 threaded ends, EN 1.4462 quality.

SHIMS

HOOKS
SAFETY QUICK RELEASE HOOKS



SHIMS

Apply shims to reduce the gap between:

- the mounting plates and the hook or swivel joint
- the hook and the swivel joint
- the hook or the swivel joint and the Henriksen adapter

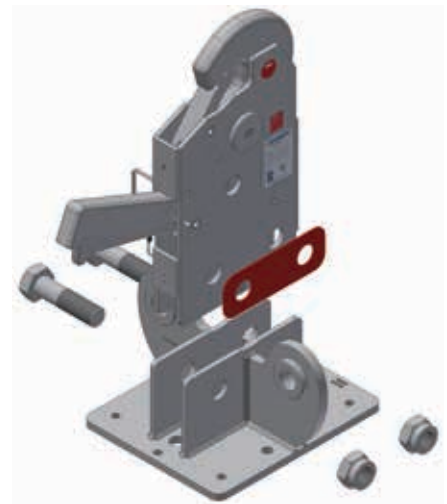
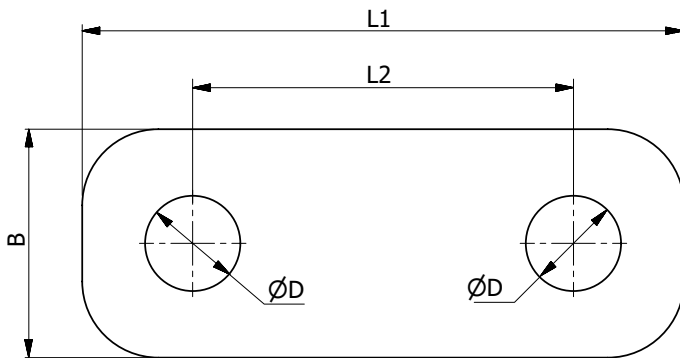

PART NO. ⁽¹⁾	SWL ⁽²⁾	L1	L2	B	ØD
HH000215	3 500 kg	158	100	60	Ø25
HH000220 ⁽³⁾	3 500 kg	126	80	40	Ø25
HH000214	5 000 kg 8 000 kg	196	120	70	Ø32
HH000213	12 000 kg	170	100	60	Ø32
HH000216	15 000 kg	190	100	70	Ø42

⁽¹⁾ 4 pcs. shims with thickness: 0,5 mm, 1 mm, 2 mm and 3 mm.

⁽²⁾ The SWL of the hook, swivel joint or adapter.

⁽³⁾ for Duplex-series.

SWIVEL JOINTS

HOOKS
SAFETY QUICK RELEASE HOOKS



HSL 3,5 / 5 / 8 / 12 / 15

The Swivel Joint is mounted in between the boat and the hook and is highly recommended on boats that are frequently used, or that may experience a sideways force during operation.

**SWIVEL HSL
JOINT**

SWIVEL JOINT

The Henriksen Swivel Joints are mounted between the Henriksen Hook and the lifting frame on the boat. The Swivel joint is designed to allow the Hook to pivot 30° (to each side) and thereby reducing the bending moment on the hook and on the lifting frame. This results in a smoother and safer experience for the operators and reduced operational risk.

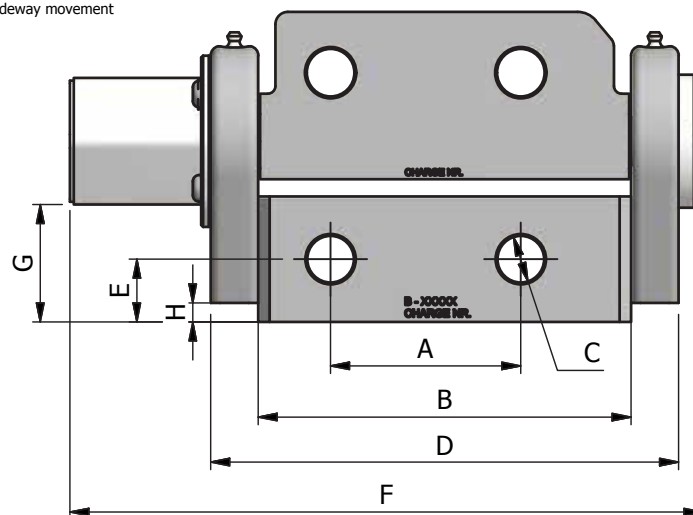
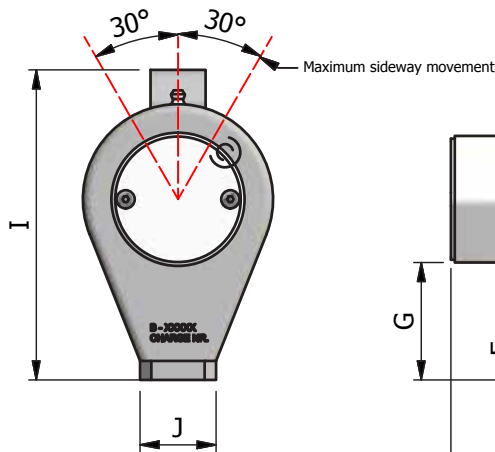

PART NO.	SWIVEL	SWL	A	B	C	D	E	F	G	H	I	J	WEIGHT
HH000106	HSL 3,5	3 500 kg	100	196	24,5	246	33	337	61	10	163	40	15,2 kg
HH000075	HSL 5/8	8 000 kg	120	246	31	296	45	397	72	15	205	45	23,0 kg
HH000074	HSL 12-35	12 000 kg	100	200	31	260	36	360	11	11	314	35	37,0 kg
HH000052	HSL 15	15 000 kg	120	248	41	308	45	410	30	15	215	50	30,5 kg

LIFTING RINGS

HOOKS
SAFETY QUICK RELEASE HOOKS



HLR 1,5 / 3,5 / 5 / 8 / 12 / 15

Henriksen lifting rings are recommended accessories for all Henriksen lifting hooks.



LIFTING RING

The Henriksen Lifting Rings are made with safety in mind. The dimensions are designed to geometrically fit together with the Henriksen Hooks. The gaps on the handles ensure a safer lifting operation. These gaps are designed to open in case of obstacles getting attached to the handle unintentionally. The gaps shall point towards the hook.

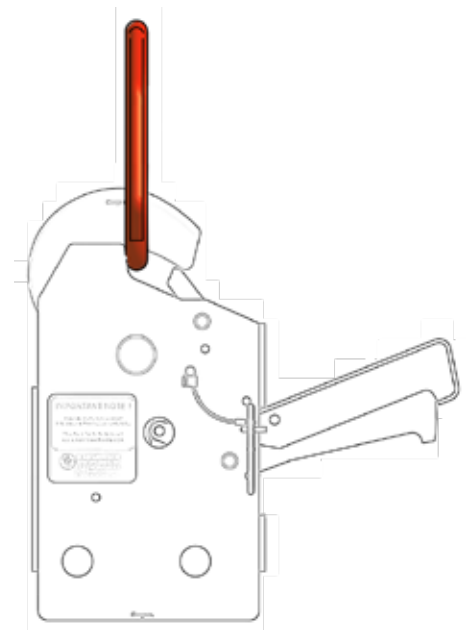
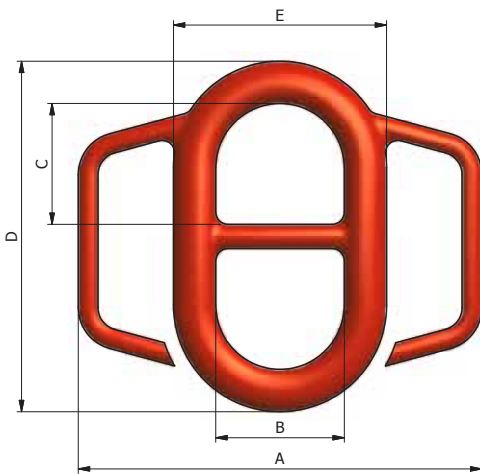

PART NO.	RING	SWL	A	B	C	D	E	F	WEIGHT
HH170657	HLR 1,5	2 000 kg	206	60	70	176	86	13	0,7 kg
HH170539	HLR 3,5	4 500 kg	226	60	81	215	100	20	1,7 kg
HH170658	HLR 5	6 000 kg	280	110	97	254	154	22	2,6 kg
HH170659	HLR 8	10 000 kg	267	85	80	232	141	28	3,2 kg
HH171814	HLRS 8	8 000 kg	143	70	40	276	143	22	2,3 kg
HH174113	HLR 10	10 000 kg	145	70	65 / 45	270	120	25	2,7 kg
HH171973	HLR 12	12 000 kg	292	110	122	266	166	28	3,7 kg
HH170660	HLR 15	15 000 kg	336	140	125	334	204	32	6,5 kg

PAINTER RINGS

HOOKS
SAFETY QUICK RELEASE HOOKS



HPR 2,5 / 5

HPRA 5

Henriksen painter rings are recommended accessories for all Henriksen painter hooks.

PAINTER RING

The Henriksen Painter Rings are made with safety in mind. The dimensions are designed to geometrically fit together with the Henriksen Hooks.

The gaps on the handles of the ring ensure a safer operation. These gaps are designed to open in case of obstacles getting attached to the handle unintentionally. The gaps shall point towards the hook.

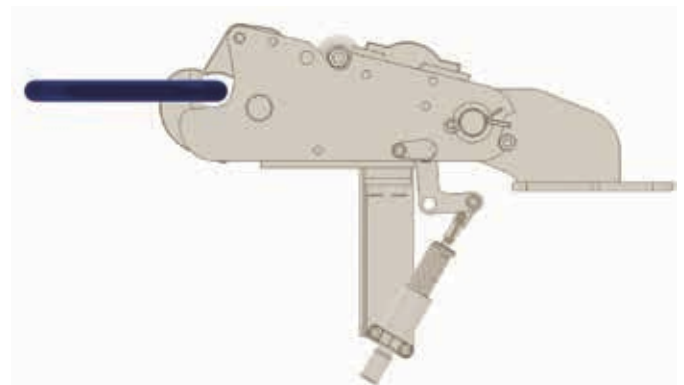
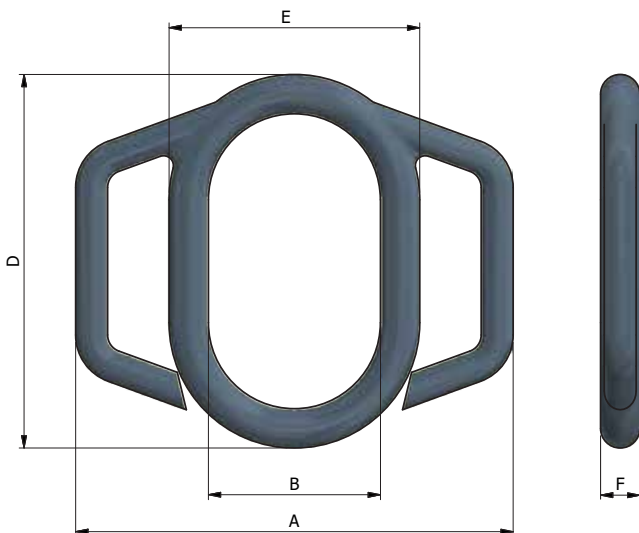

PART NO.	RING	SWL	A	B	D	E	F	WEIGHT
HH177843	HPR 2,5	4 100 kg	178	70	152	102	16	0,9 kg
HH170001	HPR 5	5 500 kg	238	82	190	122	20	1,6 kg
HH000238	HPRA 5	5 000 kg	-	-	-	-	-	-



LIFTVIEW

The Henriksen Liftview system enables the user to view in real time information about a lift, including load, tilt/roll. The user output is viewed on a screen that also logs every lift. The system contains information about the current hook, all lifts and so on.

For more information please visit
www.hhenriksen.com

HENRIKSEN

H. Henriksen AS
Træleborgveien 15
3112 Tønsberg
Phone: 333 78 400
Mail: hooks@hhenriksen.com